

# Contents

<b>4</b>	<b>The Fokker-Planck and Master Equations</b>	<b>1</b>
4.1	References . . . . .	1
4.2	Fokker-Planck Equation . . . . .	2
4.2.1	Forward and backward time equations . . . . .	2
4.2.2	Surfaces and boundary conditions . . . . .	2
4.2.3	One-dimensional Fokker-Planck equation . . . . .	3
4.2.4	Eigenfunction expansions for Fokker-Planck . . . . .	5
4.2.5	First passage problems . . . . .	9
4.2.6	Escape from a metastable potential minimum . . . . .	14
4.2.7	Detailed balance . . . . .	16
4.2.8	Multicomponent Ornstein-Uhlenbeck process . . . . .	18
4.2.9	Nyquist's theorem . . . . .	20
4.3	Master Equation . . . . .	21
4.3.1	Birth-death processes . . . . .	22
4.3.2	Examples: reaction kinetics . . . . .	23
4.3.3	Forward and reverse equations and boundary conditions . . . . .	26
4.3.4	First passage times . . . . .	28
4.3.5	From Master equation to Fokker-Planck . . . . .	30
4.3.6	Extinction times in birth-death processes . . . . .	34



## Chapter 4

# The Fokker-Planck and Master Equations

### 4.1 References

- C. Gardiner, *Stochastic Methods* (4<sup>th</sup> edition, Springer-Verlag, 2010)  
Very clear and complete text on stochastic methods, with many applications.
- N. G. Van Kampen *Stochastic Processes in Physics and Chemistry* (3<sup>rd</sup> edition, North-Holland, 2007)  
Another standard text. Very readable, but less comprehensive than Gardiner.
- Z. Schuss, *Theory and Applications of Stochastic Processes* (Springer-Verlag, 2010)  
In-depth discussion of continuous path stochastic processes and connections to partial differential equations.
- R. Mahnke, J. Kaupužs, and I. Lubashevsky, *Physics of Stochastic Processes* (Wiley, 2009)  
Introductory sections are sometimes overly formal, but a good selection of topics.

## 4.2 Fokker-Planck Equation

Here we mainly follow the discussion in chapter 5 of Gardiner, and chapter 4 of Mahnke *et al.*

### 4.2.1 Forward and backward time equations

We have already met the Fokker-Planck equation,

$$\frac{\partial P(\mathbf{x}, t | \mathbf{x}', t')}{\partial t} = -\frac{\partial}{\partial x_i} \left[ A_i(\mathbf{x}, t) P(\mathbf{x}, t | \mathbf{x}', t') \right] + \frac{1}{2} \frac{\partial^2}{\partial x_i \partial x_j} \left[ B_{ij}(\mathbf{x}, t) P(\mathbf{x}, t | \mathbf{x}', t') \right]. \quad (4.1)$$

Defining the probability flux,

$$J_i(\mathbf{x}, t | \mathbf{x}', t') = A_i(\mathbf{x}, t) P(\mathbf{x}, t | \mathbf{x}', t') - \frac{1}{2} \frac{\partial}{\partial x_j} \left[ B_{ij}(\mathbf{x}, t) P(\mathbf{x}, t | \mathbf{x}', t') \right], \quad (4.2)$$

the Fokker-Planck equation takes the form of the continuity equation,

$$\frac{\partial P(\mathbf{x}, t | \mathbf{x}', t')}{\partial t} + \nabla \cdot \mathbf{J}(\mathbf{x}, t | \mathbf{x}', t') = 0. \quad (4.3)$$

The corresponding backward Fokker-Planck equation is given by

$$-\frac{\partial P(\mathbf{x}, t | \mathbf{x}', t')}{\partial t'} = +A_i(\mathbf{x}', t') \frac{\partial P(\mathbf{x}, t | \mathbf{x}', t')}{\partial x'_i} + \frac{1}{2} B_{ij}(\mathbf{x}', t') \frac{\partial^2 P(\mathbf{x}, t | \mathbf{x}', t')}{\partial x'_i \partial x'_j}. \quad (4.4)$$

The initial conditions in both cases may be taken to be

$$P(\mathbf{x}, t | \mathbf{x}', t) = \delta(\mathbf{x} - \mathbf{x}'). \quad (4.5)$$

### 4.2.2 Surfaces and boundary conditions

#### Forward equation

Integrating Eqn. 4.3 over some region  $\Omega$ , we have

$$\frac{d}{dt} \int_{\Omega} d\mathbf{x} P(\mathbf{x}, t | \mathbf{x}', t') = - \int_{\partial\Omega} d\Sigma \hat{\mathbf{n}} \cdot \mathbf{J}(\mathbf{x}, t | \mathbf{x}', t'), \quad (4.6)$$

where  $\hat{\mathbf{n}}$  is locally normal to the surface  $\partial\Omega$ . At surfaces we need to specify boundary conditions. Generally these fall into one of three types:

- (i) *Reflecting* surfaces satisfy  $\hat{\mathbf{n}} \cdot \mathbf{J}(\mathbf{x}, t | \mathbf{x}', t')|_{\Sigma} = 0$  at the surface  $\Sigma$ .
- (ii) *Absorbing* surfaces satisfy  $P(\mathbf{x}, t | \mathbf{x}', t')|_{\Sigma} = 0$ .

(iii) *Continuity* at a surface entails

$$P(\mathbf{x}, t | \mathbf{x}', t')|_{\Sigma_+} = P(\mathbf{x}, t | \mathbf{x}', t')|_{\Sigma_-} \quad , \quad \hat{\mathbf{n}} \cdot \mathbf{J}(\mathbf{x}, t | \mathbf{x}', t')|_{\Sigma_+} = \hat{\mathbf{n}} \cdot \mathbf{J}(\mathbf{x}, t | \mathbf{x}', t')|_{\Sigma_-} . \quad (4.7)$$

These conditions on  $\mathbf{x}$  may be enforced even if the functions  $A_i(\mathbf{x}, t)$  and  $B_{ij}(\mathbf{x}, t)$  may be discontinuous across  $\Sigma$ .

### Backward equation

For the backward FPE, we have the following<sup>1</sup>:

- (i) *Reflecting* surfaces satisfy  $n_i(\mathbf{x}') B_{ij}(\mathbf{x}') \frac{\partial}{\partial x_j} P(\mathbf{x}, t | \mathbf{x}', t')|_{\Sigma} = 0$  for  $\mathbf{x}' \in \Sigma$ .
- (ii) *Absorbing* surfaces satisfy  $P(\mathbf{x}, t | \mathbf{x}', t')|_{\Sigma} = 0$ .

### 4.2.3 One-dimensional Fokker-Planck equation

Consider the Fokker-Planck equation in  $d = 1$ . On an infinite interval  $x \in (-\infty, +\infty)$ , normalization requires  $P(\pm\infty, t) = 0$ , which generally<sup>2</sup> implies  $\partial_x P(\pm\infty, t) = 0$ . On a finite interval  $x \in [a, b]$ , we may impose periodic boundary conditions  $P(a) = P(b)$  and  $J(a) = J(b)$ .

Recall that the Fokker-Planck equation follows from the stochastic differential equation

$$dx = f(x, t) dt + g(x, t) dW(t) , \quad (4.8)$$

with  $f(x, t) = A(x, t)$  and  $g(x, t) = \sqrt{B(x, t)}$ , and where  $W(t)$  is a Wiener process. In general<sup>3</sup>, a solution to the above Itô SDE exists and is unique provided the quantities  $f$  and  $g$  satisfy a *Lipschitz condition*, which says that there exists a  $K > 0$  such that  $|f(x, t) - f(y, t)| + |g(x, t) - g(y, t)| < K|x - y|$  for all  $x, y \in [a, b]$ <sup>4</sup>. Coupled with this is a *growth condition* which says that there exists an  $L > 0$  such that  $f^2(x, t) + g^2(x, t) < L(1 + x^2)$  for all  $x \in [a, b]$ . If these two conditions are satisfied for all  $t \in [0, T]$ , then there is a unique solution on this time interval.

Now suppose  $B(a, t) = 0$ , so there is no diffusion at the left endpoint. The left boundary is then said to be *prescribed*. From the Lipschitz condition on  $\sqrt{B}$ , this says that  $B(x, t)$  vanishes no slower than  $(x - a)^2$ , which says that  $\partial_x B(a, t) = 0$ . Consider the above SDE with the condition  $B(a, t) = 0$ . We see that

- (i) If  $A(a, t) > 0$ , a particle at  $a$  will enter the region  $[a, b]$  with probability one. This is called an *entrance boundary*.
- (ii) If  $A(a, t) < 0$ , a particle at  $a$  will exit the region  $[a, b]$  with probability one. This is called an *exit boundary*.

<sup>1</sup>See Gardiner, §5.1.2.

<sup>2</sup>*I.e.* for well-behaved functions which you would take home to meet your mother.

<sup>3</sup>See L. Arnold, *Stochastic Differential Equations* (Dover, 2012).

<sup>4</sup>One can choose convenient dimensionless units for all quantities.

- (iii) If  $A(a, t) = 0$ , a particle at  $a$  remain fixed with probability one. This is called a *natural boundary*.

*Mutatis mutandis*, similar considerations hold at  $x = b$ , where  $A(b, t) > 0$  for an exit and  $A(b, t) < 0$  for an entrance.

### Stationary solutions

We now look for stationary solutions  $P(x, t) = P_{\text{eq}}(x)$ . We assume  $A(x, t) = A(x)$  and  $B(x, t) = B(x)$ . Then

$$J = A(x) P_{\text{eq}}(x) - \frac{1}{2} \frac{d}{dx} [B(x) P_{\text{eq}}(x)] = \text{constant} . \quad (4.9)$$

Define the function

$$\psi(x) = \exp \left\{ 2 \int_a^x dx' \frac{A(x')}{B(x')} \right\} , \quad (4.10)$$

so  $\psi'(x) = 2\psi(x)A(x)/B(x)$ . Then

$$\frac{d}{dx} \left( \frac{B(x) P_{\text{eq}}(x)}{\psi(x)} \right) = - \frac{2J}{\psi(x)} , \quad (4.11)$$

with solution

$$P_{\text{eq}}(x) = \frac{B(a)}{B(x)} \cdot \frac{\psi(x)}{\psi(a)} \cdot P_{\text{eq}}(a) - \frac{2J \psi(x)}{B(x)} \int_a^x \frac{dx'}{\psi(x')} . \quad (4.12)$$

Note  $\psi(a) = 1$ . We now consider two different boundary conditions.

- *Zero current* : In this case  $J = 0$  and we have

$$P_{\text{eq}}(x) = \frac{B(a)}{B(x)} \cdot \frac{\psi(x)}{\psi(a)} \cdot P_{\text{eq}}(a) . \quad (4.13)$$

The unknown quantity  $P(a)$  is then determined by normalization:  $\int_a^b dx P_{\text{eq}}(x) = 1$ .

- *Periodic boundary conditions* : Here we invoke  $P(a) = P(b)$ , which requires a specific value for  $J$ ,

$$J = \frac{P_{\text{eq}}(a)}{2} \left[ \frac{B(a)}{\psi(a)} - \frac{B(b)}{\psi(b)} \right] \bigg/ \int_a^b \frac{dx'}{\psi(x')} . \quad (4.14)$$

This leaves one remaining unknown,  $P_{\text{eq}}(a)$ , which again is determined by normalization.

### Examples

We conclude this section with two examples. The first is diffusion in a gravitational field, for which the Langevin equation takes the form

$$dx = -v_D dt + \sqrt{2D} dW(t) , \quad (4.15)$$

where the drift velocity is  $v_D = g/\gamma$ , with  $\gamma$  the frictional damping constant ( $F_{\text{fr}} = -\gamma M \dot{x}$ ) and  $g$  the acceleration due to gravity. Thus, the Fokker-Planck equation is  $\partial_t P = v_D \partial_x P + D \partial_x^2 P$ , whence the solution with a reflecting ( $J = 0$ ) condition at  $x = 0$  is

$$P_{\text{eq}}(x) = \frac{v_D}{D} \exp(-v_D x/D) , \quad (4.16)$$

where we have normalized  $P(x)$  on the interval  $x \in [0, +\infty)$ . This steady state distribution reflects the fact that particles tend to fall to the bottom. If we apply instead periodic boundary conditions at  $x = 0$  and  $x = L$ , the solution is a constant  $P(x) = P(0) = P(L)$ . In this case the particles fall through the bottom  $x = 0$  only to return at the top  $x = L$  and keep falling, like in the game *Portal*<sup>5</sup>.

Our second example is that of the Ornstein-Uhlenbeck process, described by  $\partial_t P = \partial_x(\beta x P) + D \partial_x^2 P$ . The steady state solution is

$$P_{\text{eq}}(x) = P_{\text{eq}}(0) \exp(-\beta x^2/2D) . \quad (4.17)$$

This is normalizable over the real line  $x \in (-\infty, \infty)$ , in which case  $P_{\text{eq}}(0) = \sqrt{\beta/2\pi D}$ . On a finite interval  $x \in [-a, a]$  with periodic boundary conditions, we have

$$P_{\text{eq}}(x) = P_{\text{eq}}(a) e^{\beta(a^2-x^2)/2D} . \quad (4.18)$$

#### 4.2.4 Eigenfunction expansions for Fokker-Planck

We saw in §4.2.1 how the (forward) Fokker-Planck equation could be written as

$$\frac{\partial P(x,t)}{\partial t} = \mathcal{L} P(x,t) \quad , \quad \mathcal{L} = -\frac{\partial}{\partial x} A(x) + \frac{1}{2} \frac{\partial^2}{\partial x^2} B(x) , \quad (4.19)$$

and how the stationary state solution  $P_{\text{eq}}(x)$  satisfies  $J = A P_{\text{eq}} - \frac{1}{2} \partial_x (B P_{\text{eq}})$ . Consider the operator

$$\tilde{\mathcal{L}} = +A(x) \frac{\partial}{\partial x} + \frac{1}{2} B(x) \frac{\partial^2}{\partial x^2} , \quad (4.20)$$

where, relative to  $\mathcal{L}$ , the sign of the leading term is reversed. It is straightforward to show that, for any functions  $f$  and  $g$ ,

$$\langle f | \tilde{\mathcal{L}} | g \rangle - \langle g | \mathcal{L} | f \rangle = \left[ g J_f - f K_g \right]_a^b , \quad (4.21)$$

where

$$\langle g | \mathcal{L} | f \rangle = \int_a^b dx g(x) \mathcal{L} f(x) , \quad (4.22)$$

---

<sup>5</sup>The cake is a lie.

and  $J_f = Af - \frac{1}{2}(Bf)'$  and  $K_g = -\frac{1}{2}Bg'$ . Thus we conclude that  $\tilde{\mathcal{L}} = \mathcal{L}^\dagger$ , the adjoint of  $\mathcal{L}$ , if either (i)  $J_f$  and  $K_g$  vanish at the boundaries  $x = a$  and  $x = b$  (reflecting conditions), or (ii) the functions  $f$  and  $g$  vanish at the boundaries (absorbing conditions).

We can use the zero current steady state distribution  $P_{\text{eq}}(x)$ , for which  $J = AP_{\text{eq}} - \frac{1}{2}\partial_x(BP_{\text{eq}}) = 0$ , to convert between solutions of the forward and backward time Fokker-Planck equations. Suppose  $P(x, t)$  satisfies  $\partial_t P = \mathcal{L}P$ . Then define  $Q(x, t) \equiv P(x, t)/P_{\text{eq}}(x)$ , in which case

$$\begin{aligned} \partial_t P &= P_{\text{eq}} \partial_t Q = -\partial_x(AP_{\text{eq}}Q) + \frac{1}{2}\partial_x^2(BP_{\text{eq}}Q) \\ &= \left\{ -\partial_x(AP_{\text{eq}}) + \frac{1}{2}\partial_x^2(BP_{\text{eq}}) \right\} Q + \left\{ -A\partial_x Q + \frac{1}{2}B\partial_x^2 Q \right\} P_{\text{eq}} + \partial_x(BP_{\text{eq}}) \partial_x Q \\ &= \left\{ A\partial_x Q + \frac{1}{2}B\partial_x^2 Q \right\} P_{\text{eq}}, \end{aligned} \quad (4.23)$$

where we have used  $\partial_x(BP_{\text{eq}}) = 2AP_{\text{eq}}$ . Thus, we have that  $Q(x, t)$  satisfies  $\partial_t Q = \tilde{\mathcal{L}}Q$ . We saw in §4.2.1 how the (forward) Fokker-Planck equation could be written as

$$\frac{\partial Q(x, t)}{\partial t} = \mathcal{L}^\dagger Q(x, t) \quad , \quad \mathcal{L}^\dagger = A(x) \frac{\partial}{\partial x} + \frac{1}{2} B(x) \frac{\partial^2}{\partial x^2}, \quad (4.24)$$

which is the backward Fokker-Planck equation when written in terms of the time variable  $s = -t$ .

Now let us seek eigenfunctions  $P_n(x)$  and  $Q_n(x)$  which satisfy<sup>6</sup>

$$\mathcal{L}P_n(x) = -\lambda_n P_n(x) \quad , \quad \mathcal{L}^\dagger Q_n(x) = -\lambda_n Q_n(x) \quad . \quad (4.25)$$

where now  $A(x, t) = A(x)$  and  $B(x, t) = B(x)$  are assumed to be time-independent. If the functions  $P_n(x)$  and  $Q_n(x)$  form complete sets, then a solution to the Fokker-Planck equations for  $P(x, t)$  and  $Q(x, t)$  is of the form<sup>7</sup>

$$P(x, t) = \sum_n C_n P_n(x) e^{-\lambda_n t} \quad , \quad Q(x, t) = \sum_n C_n Q_n(x) e^{-\lambda_n t} \quad . \quad (4.26)$$

To elicit the linear algebraic structure here, we invoke Eqn. 4.25 and write

$$(\lambda_m - \lambda_n) Q_m(x) P_n(x) = Q_m(x) \mathcal{L} P_n(x) - P_n(x) \mathcal{L}^\dagger Q_m(x) . \quad (4.27)$$

Next we integrate over the interval  $[a, b]$ , which gives

$$(\lambda_m - \lambda_n) \int_a^b dx Q_m(x) P_n(x) = \left[ Q_m(x) J_n(x) - K_m(x) P_n(x) \right]_a^b = 0 , \quad (4.28)$$

where  $J_n(x) = A(x) P_n(x) - \frac{1}{2}\partial_x[B(x) P_n(x)]$  and  $K_m(x) = -\frac{1}{2}B(x) \partial_x Q_m(x)$ . For absorbing boundary conditions, the functions  $P_n(x)$  and  $Q_n(x)$  vanish at  $x = a$  and  $x = b$ , so the RHS above vanishes. For

<sup>6</sup>In the eigensystem, the partial differential operators  $\frac{\partial}{\partial x}$  in  $\mathcal{L}$  and  $\mathcal{L}^\dagger$  may be regarded as ordinary differential operators  $\frac{d}{dx}$ .

<sup>7</sup>Since  $P_n(x) = P_{\text{eq}}(x) Q_n(x)$ , the same expansion coefficients  $\{C_n\}$  appear in both sums.



reflecting boundaries, it is the currents  $J_n$  and  $K_m(x)$  which vanish at the boundaries. Thus we have  $(\lambda_m - \lambda_n) \langle Q_m | P_n \rangle = 0$ , where the inner product is

$$\langle Q | P \rangle \equiv \int_a^b dx Q(x) P(x). \quad (4.29)$$

We obtain the familiar result from Sturm-Liouville theory that when the eigenvalues differ, the corresponding eigenfunctions are orthogonal. In the case of eigenvalue degeneracy, we can invoke the Gram-Schmidt procedure, in which case we may adopt the general normalization

$$\langle Q_m | P_n \rangle = \int_a^b dx Q_m(x) P_n(x) = \int_a^b dx P_{\text{eq}}(x) Q_m(x) Q_n(x) = \int_a^b dx \frac{P_m(x) P_n(x)}{P_{\text{eq}}(x)} = \delta_{mn}. \quad (4.30)$$

A general solution to the Fokker-Planck equation with reflecting boundaries may now be written as

$$P(x, t) = \sum_n C_n P_n(x) e^{-\lambda_n t}, \quad (4.31)$$

where the expansion coefficients  $\{C_n\}$  are given by

$$C_n = \int_a^b dx Q_n(x) P(x, 0) = \langle Q_n | P(0) \rangle. \quad (4.32)$$

Suppose our initial condition is  $P(x, 0 | x_0, 0) = \delta(x - x_0)$ . Then  $C_n = Q_n(x_0)$ , and

$$P(x, t | x_0, 0) = \sum_n Q_n(x_0) P_n(x) e^{-\lambda_n t}. \quad (4.33)$$

We may now take averages, such as

$$\langle F(x(t)) \rangle = \int_a^b dx F(x) \sum_n Q_n(x_0) P_n(x) e^{-\lambda_n t}. \quad (4.34)$$

Furthermore, if we also average over  $x_0 = x(0)$ , assuming it is distributed according to  $P_{\text{eq}}(x_0)$ , we have the correlator

$$\begin{aligned} \langle x(t) x(0) \rangle &= \int_a^b dx_0 \int_a^b dx x x_0 P(x, t | x_0, 0) P_{\text{eq}}(x_0) \\ &= \sum_n \left[ \int_a^b dx x P_n(x) \right]^2 e^{-\lambda_n t} = \sum_n |\langle x | P_n \rangle|^2 e^{-\lambda_n t}. \end{aligned} \quad (4.35)$$

### Absorbing boundaries

At an *absorbing boundary*  $x = a$ , one has  $P(a) = Q(a) = 0$ . We may still use the function  $P_{\text{eq}}(x)$  obtained from the  $J = 0$  reflecting boundary conditions to convert between forward and backward Fokker-Planck equation solutions.

Next we consider some simple examples of the eigenfunction formalism.

### Heat equation

We consider the simplest possible Fokker-Planck equation,

$$\frac{\partial P}{\partial t} = D \frac{\partial^2 P}{\partial x^2}, \quad (4.36)$$

which is of course the one-dimensional diffusion equation. We choose our interval to be  $x \in [0, L]$ .

- *Reflecting boundaries* : The normalized steady state solution is simply  $P_{\text{eq}}(x) = 1/L$ . The eigenfunctions are  $P_0(x) = P_{\text{eq}}(x)$  and

$$P_n(x) = \frac{\sqrt{2}}{L} \cos\left(\frac{n\pi x}{L}\right), \quad Q_n(x) = \sqrt{2} \cos\left(\frac{n\pi x}{L}\right) \quad (4.37)$$

for  $n > 0$ . The eigenvalues are  $\lambda_n = D(n\pi/L)^2$ . We then have

$$P(x, t | x_0, 0) = \frac{1}{L} + \frac{2}{L} \sum_{n=1}^{\infty} \cos\left(\frac{n\pi x_0}{L}\right) \cos\left(\frac{n\pi x}{L}\right) e^{-\lambda_n t}. \quad (4.38)$$

Note that as  $t \rightarrow \infty$  one has  $P(x, \infty | x_0, 0) = 1/L$ , which says that  $P(x, t)$  relaxes to  $P_{\text{eq}}(x)$ . Both boundaries are natural boundaries, which prevent probability flux from entering or leaking out of the region  $[0, L]$ .

- *Absorbing boundaries* : Now we have

$$P_n(x) = \frac{\sqrt{2}}{L} \sin\left(\frac{n\pi x}{L}\right), \quad Q_n(x) = \sqrt{2} \sin\left(\frac{n\pi x}{L}\right) \quad (4.39)$$

and

$$P(x, t | x_0, 0) = \frac{2}{L} \sum_{n=1}^{\infty} \sin\left(\frac{n\pi x_0}{L}\right) \sin\left(\frac{n\pi x}{L}\right) e^{-\lambda_n t}, \quad (4.40)$$

again with  $\lambda_n = D(n\pi/L)^2$ . Since  $\lambda_n > 0$  for all allowed  $n$ , we have  $P(x, \infty | x_0, 0) = 0$ , and all the probability leaks out by diffusion. The current is  $J(x) = -DP'(x)$ , which does not vanish at the boundaries.

- *Mixed boundaries* : Now suppose  $x = 0$  is an absorbing boundary and  $x = L$  a reflecting boundary. Then

$$P_n(x) = \frac{\sqrt{2}}{L} \sin\left(\frac{(2n+1)\pi x}{2L}\right) \quad , \quad Q_n(x) = \sqrt{2} \sin\left(\frac{(2n+1)\pi x}{2L}\right) \quad (4.41)$$

with  $n \geq 0$ . The eigenvalues are  $\lambda_n = D \left((n + \frac{1}{2}) \pi/L\right)^2$ .

We can write the eigenfunctions in all three cases in the form  $P_n(x) = \frac{\sqrt{2}}{L} \sin(k_n x + \delta)$ , where  $k_n = n\pi/L$  or  $(n + \frac{1}{2})\pi/L$  and  $\delta = 0$  or  $\delta = \frac{1}{2}\pi$ , with  $\lambda_n = D k_n^2$ . One then has

$$\langle x | P_n \rangle = \begin{cases} \frac{1}{2}L & \text{reflecting, } n = 0 \\ -(\sqrt{8}/L k_n^2) \delta_{n,\text{odd}} & \text{reflecting, } n > 0 \\ (-1)^{n+1} \sqrt{2}/k_n & \text{absorbing, } n > 0 \\ (-1)^{n+1} \sqrt{2}/L k_n^2 & \text{half reflecting, half absorbing, } n > 0. \end{cases} \quad (4.42)$$

Note that when a zero mode  $\lambda_{\min} = 0$  is part of the spectrum, one has  $P_0(x) = P_{\text{eq}}(x)$ , to which  $P(x, t)$  relaxes in the  $t \rightarrow \infty$  limit. When one or both of the boundaries is absorbing, the lowest eigenvalue  $\lambda_{\min} > 0$  is finite, hence  $P(x, t \rightarrow \infty) \rightarrow 0$ , *i.e.* all the probability eventually leaks out of the interval.

### Ornstein-Uhlenbeck process

The Fokker-Planck equation for the OU process is  $\partial_t P = \partial_x(\beta x P) + D \partial_x^2 P$ . Over the real line  $x \in \mathbb{R}$ , the normalized steady state distribution is  $P_{\text{eq}}(x) = (\beta/2\pi D)^{1/2} \exp(-\beta x^2/2D)$ . The eigenvalue equation for  $Q_n(x)$  is

$$D \frac{d^2 Q_n}{dx^2} - \beta x \frac{dQ_n}{dx} = -\lambda_n Q_n(x). \quad (4.43)$$

Changing variables to  $\xi = x/\ell$ , where  $\ell = (2D/\beta)^{1/2}$ , we obtain  $Q_n'' - 2\xi Q_n' + (2\lambda_n/\beta) Q_n = 0$ , which is Hermite's equation. The eigenvalues are  $\lambda_n = n\beta$ , and the normalized eigenfunctions are then

$$\begin{aligned} Q_n(x) &= \frac{1}{\sqrt{2^n n!}} H_n(x/\ell) \\ P_n(x) &= \frac{1}{\sqrt{2^n n!} \pi \ell^2} H_n(x/\ell) e^{-x^2/\ell^2}, \end{aligned} \quad (4.44)$$

which satisfy the orthonormality relation  $\langle Q_m | P_n \rangle = \delta_{mn}$ . Since  $H_1(\xi) = 2\xi$ , one has  $\langle x | P_n \rangle = (\ell/\sqrt{2}) \delta_{n,1}$ , hence the correlator is given by  $\langle x(t) x(0) \rangle = \frac{1}{2} \ell^2 e^{-\beta t}$ .

#### 4.2.5 First passage problems

Suppose we have a particle on an interval  $x \in [a, b]$  with absorbing boundary conditions, which means that particles are removed as soon as they get to  $x = a$  or  $x = b$  and not replaced. Following Gardiner<sup>8</sup>,

<sup>8</sup>See Gardiner §5.5.

define the quantity

$$G(x, t) = \int_a^b dx' P(x', t | x, 0). \quad (4.45)$$

Thus,  $G(x, t)$  is the probability that  $x(t) \in [a, b]$  given that  $x(0) = x$ . Since the boundary conditions are absorbing, there is no reentrance into the region, which means that  $G(x, t)$  is strictly decreasing as a function of time, and that

$$-\frac{\partial G(x, t)}{\partial t} dt = \text{probability, starting from } x \text{ at } t = 0, \text{ to exit } [a, b] \text{ during time interval } [t, t + dt]. \quad (4.46)$$

If we assume the process is autonomous, then

$$G(x, t) = \int_a^b dx' P(x', 0 | x, -t), \quad (4.47)$$

which satisfies the backward Fokker-Planck equation,

$$\frac{\partial G}{\partial t} = A \frac{\partial G}{\partial x} + \frac{1}{2} B \frac{\partial^2 G}{\partial x^2} = \mathcal{L}^\dagger G. \quad (4.48)$$

We may average functions of the exit time  $t$  according to

$$\langle f(t) \rangle_x = \int_0^\infty dt f(t) \left( -\frac{\partial G(x, t)}{\partial t} \right). \quad (4.49)$$

In particular, the *mean exit time*  $T(x)$  is given by

$$T(x) = \langle t \rangle_x = \int_0^\infty dt t \left( -\frac{\partial G(x, t)}{\partial t} \right) = \int_0^\infty dt G(x, t). \quad (4.50)$$

From the Fokker-Planck equation for  $G(x, t)$ , the mean exit time  $T(x)$  satisfies the ODE

$$\frac{1}{2} B(x) \frac{d^2 T}{dx^2} + A(x) \frac{dT}{dx} = -1. \quad (4.51)$$

This is derived by applying the operator  $\mathcal{L}^\dagger = \frac{1}{2} B(x) \frac{\partial^2}{\partial x^2} + A(x) \frac{\partial}{\partial x}$  to the above expression for  $T(x)$ . Acting on the integrand  $G(x, t)$ , this produces  $\frac{\partial G}{\partial t}$ , according to Eq. 4.48, hence  $\int_0^\infty dt \partial_t G(x, t) = G(x, \infty) - G(x, 0) = -1$ .

To solve Eqn. 4.51, we once again invoke the services of the function

$$\psi_1(x) = \exp \left\{ \int_a^x dx' \frac{2A(x')}{B(x')} \right\}, \quad (4.52)$$

which satisfies  $\psi_1'(x)/\psi_1(x) = 2A(x)/B(x)$ . Thus, we may reexpress eqn. 4.51 as

$$T'' + \frac{\psi_1'}{\psi_1} T' = -\frac{2}{B} \quad \Rightarrow \quad (\psi_1 T')' = -\frac{2\psi_1}{B}. \quad (4.53)$$

We may integrate this to obtain

$$T'(x) = \frac{T'(a)}{\psi_1(x)} - \frac{\psi_2(x)}{\psi_1(x)}, \quad (4.54)$$

where we have defined

$$\psi_2(x) = 2 \int_a^x dx' \frac{\psi_1(x')}{B(x')}. \quad (4.55)$$

Note that  $\psi_1(a) = 1$  and  $\psi_2(a) = 0$ . We now integrate one last time to obtain

$$T(x) = T(a) + T'(a) \psi_3(x) - \psi_4(x), \quad (4.56)$$

where

$$\psi_3(x) = \int_a^x \frac{dx'}{\psi_1(x')} \quad , \quad \psi_4(x) = \int_a^x dx' \frac{\psi_2(x')}{\psi_1(x')}. \quad (4.57)$$

Note that  $\psi_3(a) = \psi_4(a) = 0$

Eqn. 4.56 involves two constants of integration,  $T(a)$  and  $T'(a)$ , which are to be determined by imposing two boundary conditions. If the boundaries are absorbing, we have  $T(a) = T(b) = 0$ , which entail  $T'(a) = \psi_4(b)/\psi_3(b)$ . The final result for the mean exit time is then

$$T(x) = \frac{\psi_3(x) \psi_4(b) - \psi_3(b) \psi_4(x)}{\psi_3(b)}. \quad (4.58)$$

As an example, consider the case of pure diffusion:  $A(x) = 0$  and  $B(x) = 2D$ . Then

$$\psi_1(x) = 1 \quad , \quad \psi_2(x) = (x-a)/D \quad , \quad \psi_3(x) = (x-a) \quad , \quad \psi_4(x) = (x-a)^2/2D, \quad (4.59)$$

whence

$$T(x) = \frac{(x-a)(b-x)}{2D}. \quad (4.60)$$

A particle starting in the middle  $x = \frac{1}{2}(a+b)$  at time  $t = 0$  will then exit the region in an average time  $(b-a)^2/8D$ .

### One absorbing, one reflecting boundary

Suppose the boundary at  $a$  is now reflecting, while that at  $b$  remains absorbing. We then have the boundary conditions  $\partial_x G(a, t) = 0$  and  $G(b, t) = 0$ , which entail  $T'(a) = 0$  and  $T(b) = 0$ . Then the general result of Eqn. 4.56 then gives  $T(x) = T(a) - \psi_4(x)$ . Requiring  $T(b) = 0$  then yields the result

$$T(x) = T(b) - \psi_4(x) = 2 \int_x^b \frac{dy}{\psi_1(y)} \int_a^y \frac{\psi_1(z)}{B(z)} \quad (x = a \text{ reflecting}, x = b \text{ absorbing}). \quad (4.61)$$

Under the opposite condition, where the boundary at  $a$  is absorbing while that at  $b$  is reflecting, we have  $T(a) = 0$  and  $T'(b) = 0$ . Eqn. 4.56 then gives  $T(x) = T'(a) \psi_3(x) - \psi_4(x)$ , and imposing  $T'(b) = 0$  entails  $T'(a) = \psi_2(b)$ , hence

$$T(x) = \psi_2(b) \psi_3(x) - \psi_4(x) = 2 \int_a^x \frac{dy}{\psi_1(y)} \int_y^b dz \frac{\psi_1(z)}{B(z)} \quad (x = a \text{ absorbing, } x = b \text{ reflecting}). \quad (4.62)$$

### Escape through either boundary

Define the quantities

$$\begin{aligned} G_a(x, t) &= - \int_t^\infty dt' J(a, t' | x, 0) = \int_t^\infty dt' \left\{ -A(a) P(a, t' | x, 0) + \frac{1}{2} \partial_a [B(a) P(a, t' | x, 0)] \right\} \\ G_b(x, t) &= + \int_t^\infty dt' J(b, t' | x, 0) = \int_t^\infty dt' \left\{ +A(b) P(b, t' | x, 0) - \frac{1}{2} \partial_b [B(b) P(b, t' | x, 0)] \right\}. \end{aligned} \quad (4.63)$$

Since  $-J(a, t | x, 0)$  is the left-moving probability flux at  $x = a$ ,  $G_a(x, t)$  represents the probability that a particle starting at  $x \in [a, b]$  exits at  $a$  sometime after a time  $t$ . The second expression for  $G_b(x, t)$  yields the probability that a particle starting at  $x$  exits at  $b$  sometime after  $t$ . Their sum is

$$\begin{aligned} G_a(x, t) + G_b(x, t) &= \int_t^\infty dt' \int_a^b dx' \partial_{x'} \left\{ A(x') P(x', t' | x, 0) - \frac{1}{2} \partial_{x'} [B(x') P(x', t' | x, 0)] \right\} \\ &= \int_t^\infty dt' \int_a^b dx' \left[ -\partial_{x'} P(x', t' | x, 0) \right] = \int_a^b dx' P(x', t | x, 0) = G(x, t), \end{aligned} \quad (4.64)$$

which is the total probability starting from  $x$  to exit the region after  $t$ .

Since  $P(a, t' | x, 0)$  satisfies the backward Fokker-Planck equation, *i.e.*  $\mathcal{L}^\dagger P(a, t' | x, 0) = \partial_{t'} P(a, t' | x, 0)$ , we have

$$\begin{aligned} \mathcal{L}^\dagger G_a(x, t) &= J(a, t | x, 0) = +\partial_t G_a(x, t) \\ \mathcal{L}^\dagger G_b(x, t) &= J(b, t | x, 0) = -\partial_t G_b(x, t). \end{aligned} \quad (4.65)$$

Now let us evaluate the above equations in the limit  $t \rightarrow 0$ . Since  $P(x', 0 | x, 0) = \delta(x - x')$ , there can only be an infinitesimal particle current at any finite distance from the initial point  $x$  at an infinitesimal value of the elapsed time  $t$ . Therefore we have

$$\mathcal{L}^\dagger G_c(x, 0) = \left\{ A(x) \frac{\partial}{\partial x} + \frac{1}{2} B(x) \frac{\partial^2}{\partial x^2} \right\} G_c(x, 0) = 0. \quad (4.66)$$

Thus,  $G_c(x, 0)$  is the total probability for exit via  $c \in \{a, b\}$  over all time, conditioned at starting at  $x$  at time 0. The boundary conditions here are

$$G_a(a, 0) = 1 \quad , \quad G_a(b, 0) = 0 \quad ; \quad G_b(b, 0) = 1 \quad , \quad G_b(a, 0) = 0 \quad , \quad (4.67)$$

which says that a particle starting at  $a$  is immediately removed with probability unity and therefore can never exit through  $b$ , and *vice versa*. Solving using the function  $\psi_1(x) = \exp \int_a^x dx 2A(x')/B(x')$ , we have

$$\begin{aligned} G_a(x, 0) &= \int_x^b dy \psi_1(y) / \int_a^b dz \psi_1(z) \\ G_b(x, 0) &= \int_a^x dy \psi_1(y) / \int_a^b dz \psi_1(z) . \end{aligned} \quad (4.68)$$

Note  $G_a(x, 0) + G_b(x, 0) = 1$ , which says that eventually the particle exits via either  $a$  or  $b$ . We next define

$$T_c(x) = \int_0^\infty dt \frac{G_c(x, t)}{G_c(x, 0)} , \quad (4.69)$$

which is the mean exit time through  $c$ , given that the particle did exit through that boundary. This then satisfies

$$\mathcal{L}^\dagger [G_c(x, 0) T_c(x)] = -G_c(x, 0) . \quad (4.70)$$

For pure diffusion,  $A(x) = 0$  and  $B(x) = 2D$ , and we found  $\psi_1(x) = 1$ . Therefore

$$G_a(x, 0) = \frac{b-x}{b-a} \quad , \quad G_b(x, 0) = \frac{x-a}{b-a} . \quad (4.71)$$

We may then solve the equations

$$D \frac{d^2}{dx^2} [G_c(x, 0) T_c(x)] = -G_c(x, 0) \quad (4.72)$$

to obtain

$$T_a(x) = \frac{(x-a)(2b-x-a)}{6D} \quad , \quad T_b(x) = \frac{(b-x)(b+x-2a)}{6D} . \quad (4.73)$$

Note that

$$G_a(x, 0) T_a(x) + G_b(x, 0) T_b(x) = \frac{(x-a)(b-x)}{2D} = T(x) , \quad (4.74)$$

which we found previously in Eqn. 4.60.

### 4.2.6 Escape from a metastable potential minimum

In the presence of a local potential  $U(x)$ , the local drift velocity is  $-U'(x)/\gamma m$ , where  $m$  is the particle's mass and  $\gamma$  its frictional damping ( $F_{\text{fr}} = -\gamma m \dot{x}$ ). An example potential  $U(x)$  is depicted in Fig. 4.1. Gardiner in §5.5.3 begins with the equation

$$\frac{\partial P}{\partial t} = \frac{\partial}{\partial x} \left( \frac{U'(x)}{\gamma m} P \right) + D \frac{\partial^2 P}{\partial x^2} \quad , \quad (4.75)$$

which resembles a Fokker-Planck equation for  $P(x, t)$  with drift  $v_D(x) = -U'(x)/\gamma m$ . However, Eqn. 4.75 is not a Fokker-Planck equation but rather something called the *Smoluchowski equation*. Recall that the position  $x(t)$  of a Brownian particle *does not execute a Markov process*. So where does Eqn. 4.75 come from, and under what conditions is it valid?

It is the two-component phase space vector  $\varphi = (x, v)$  which executes a Markov process, and for whose conditional probability density we can derive a Fokker-Planck equation, and not the position  $x$  alone. The Brownian motion problem may be written as two coupled first order differential equations,

$$\begin{aligned} dx &= v dt \\ dv &= - \left[ \frac{1}{m} U'(x) + \gamma v \right] dt + \sqrt{\Gamma} dW(t) \quad , \end{aligned} \quad (4.76)$$

where  $\Gamma = 2\gamma k_B T/m = 2\gamma^2 D$ , and where  $W(t)$  is a Wiener process. The first of these is an ODE and the second an SDE. Viewed as a multicomponent SDE, the Fokker-Planck equation for  $P(x, v, t)$  is

$$\frac{\partial P}{\partial t} = - \frac{\partial}{\partial x} (vP) + \frac{\partial}{\partial v} \left[ \left( \frac{U'(x)}{m} + \gamma v \right) P \right] + \frac{\gamma k_B T}{m} \frac{\partial^2 P}{\partial v^2} \quad . \quad (4.77)$$

Suppose though that the damping  $\gamma$  is large. Then we can *approximate* the second equation in 4.76 by assuming  $v$  rapidly relaxes, which is to say  $dv \approx 0$ . Then we have

$$v dt \approx - \frac{1}{\gamma m} U'(x) dt + \sqrt{2D} dW(t) \quad (4.78)$$

and replacing  $v dt$  in the first equation with this expression we obtain the SDE

$$dx = v_D(x) dt + \sqrt{2D} dW(t) \quad , \quad (4.79)$$

which immediately yields the Smoluchowski equation 4.75. This procedure is tantamount to an adiabatic elimination of the fast variable. It is valid only in the limit of large damping  $\gamma = 6\pi\eta a/m$ , which is to say large fluid viscosity  $\eta$ .

Taking the Smoluchowski equation as our point of departure, the steady state distribution is then found to be

$$P_{\text{eq}}(x) = C e^{-U(x)/k_B T} \quad , \quad (4.80)$$

where we invoke the result  $D = k_B T/\gamma m$  from §2.2.2. We now consider the first passage time  $T(x | x_0)$  for a particle starting at  $x = x_0$  escaping to a point  $x \approx x^*$  in the vicinity of the local potential maximum. We



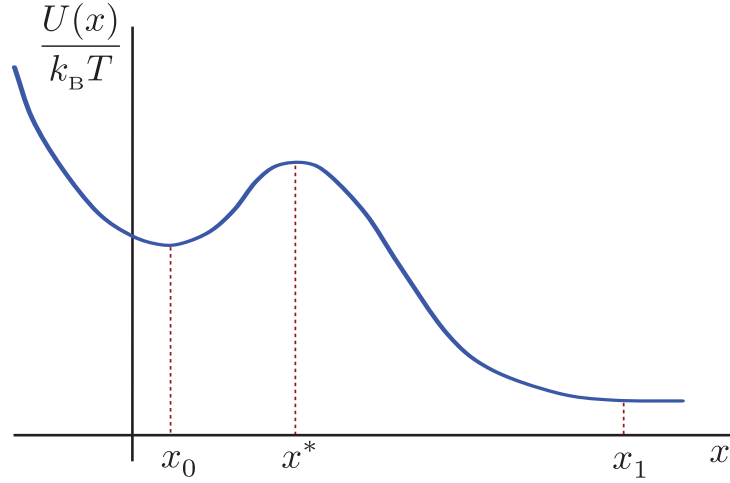

Figure 4.1: Escape from a metastable potential minimum.

apply the result of our previous analysis, with  $(a, b, x)$  in Eqn. 4.61 replaced by  $(-\infty, x, x_0)$ , respectively, and  $x \gtrsim x^*$ . Note that  $A(x) = -U'(x)/\gamma m$ , and  $B(x) = 2D$ , hence

$$\ln \psi_1(x) = \int_a^x dx' \frac{2A(x')}{B(x')} = \frac{U(a) - U(x)}{k_B T} . \quad (4.81)$$

Formally we may have  $U(a) = \infty$ , but it drops out of the expression for the mean exit time,

$$T(x | x_0) = \frac{1}{D} \int_{x_0}^x \frac{dy}{\psi_1(y)} \int_{-\infty}^y dz \psi_1(z) = \frac{1}{D} \int_{x_0}^x dy e^{U(y)/k_B T} \int_{-\infty}^y dz e^{-U(z)/k_B T} . \quad (4.82)$$

The above integrals can be approximated as follows. Expand  $U(x)$  about the local extrema at  $x_0$  and  $x^*$  as

$$\begin{aligned} U(x_0 + \delta x) &= U(x_0) + \frac{1}{2} K_0 (\delta x)^2 + \dots \\ U(x^* + \delta x) &= U(x^*) - \frac{1}{2} K^* (\delta x)^2 + \dots , \end{aligned} \quad (4.83)$$

where  $K_0 = U''(x_0)$  and  $K^* = -U''(x^*)$ . At low temperatures, integrand  $e^{-U(z)/k_B T}$  is dominated by the region  $z \approx x_0$ , hence

$$\int_{-\infty}^y dz e^{-U(z)/k_B T} \approx \left( \frac{2\pi k_B T}{K_0} \right)^{1/2} e^{-U(x_0)/k_B T} . \quad (4.84)$$

Similarly, the integrand  $e^{U(y)/k_B T}$  is dominated by the region  $y \approx x^*$ , so for  $x$  somewhere between  $x^*$  and  $x_1$ , we may write<sup>9</sup>

$$\int_{x_0}^x dy e^{U(y)/k_B T} \approx \left( \frac{2\pi k_B T}{K^*} \right)^{1/2} e^{U(x^*)/k_B T} . \quad (4.85)$$

<sup>9</sup>We take  $x > x^*$  to lie somewhere on the downslope of the potential curve, on the other side of the barrier from the metastable minimum.

We then have

$$T(x_1 | x_0) \approx \frac{2\pi k_B T}{D \sqrt{K_0 K^*}} \exp\left(\frac{U(x^*) - U(x_0)}{k_B T}\right). \quad (4.86)$$

Known as the *Arrhenius law*, this is one of the most ubiquitous results in nonequilibrium statistical physics, with abundant consequences for chemistry, biology, and many other fields of science. With  $\Delta E = U(x^*) - U(x_0)$ , the energy necessary to surmount the barrier, the escape *rate* is seen to be proportional to  $\exp(-\Delta E/k_B T)$ .

### 4.2.7 Detailed balance

Let  $\varphi$  denote a coordinate vector in phase space. In classical mechanics,  $\varphi = (q, p)$  consists of all the generalized coordinates and generalized momenta. The condition of *detailed balance* says that each individual transition balances precisely with its time reverse, resulting in no net probability currents in equilibrium. Note that this is a much stronger condition than conservation of probability.

In terms of joint probability densities, detailed balance may be stated as follows:

$$P(\varphi, t; \varphi', t') = P(\varphi'^T, -t'; \varphi^T, -t) = P(\varphi'^T, t; \varphi^T, t'), \quad (4.87)$$

where we have assumed time translation invariance. Here,  $\varphi^T$  is the time reverse of  $\varphi$ . This is accomplished by multiplying each component  $\varphi_i$  by a quantity  $\varepsilon_i = \pm 1$ . For positions  $\varepsilon = +1$ , while for momenta  $\varepsilon = -1$ . If we define the diagonal matrix  $\varepsilon_{ij} = \varepsilon_i \delta_{ij}$  (no sum on  $i$ ), then  $\varphi_i^T = \varepsilon_{ij} \varphi_j$  (implied sum on  $j$ ). Thus we may rewrite the above equation as

$$P(\varphi, t; \varphi', t') = P(\varepsilon \varphi', t; \varepsilon \varphi, t'). \quad (4.88)$$

In terms of the conditional probability distributions, we have

$$P(\varphi, t | \varphi', 0) P_{\text{eq}}(\varphi') = P(\varepsilon \varphi', t | \varepsilon \varphi, 0) P_{\text{eq}}(\varepsilon \varphi), \quad (4.89)$$

where  $P_{\text{eq}}(\varphi)$  is the equilibrium distribution, which we assume holds at time  $t' = 0$ . Now in the limit  $t \rightarrow 0$  we have  $P(\varphi, t \rightarrow 0 | \varphi', 0) = \delta(\varphi - \varphi')$ , and we therefore conclude

$$P_{\text{eq}}(\varepsilon \varphi) = P_{\text{eq}}(\varphi). \quad (4.90)$$

The equilibrium distribution  $P_{\text{eq}}(\varphi)$  is time-reversal invariant. Thus, detailed balance entails

$$P(\varphi, t | \varphi', 0) P_{\text{eq}}(\varphi') = P(\varepsilon \varphi', t | \varepsilon \varphi, 0) P_{\text{eq}}(\varphi). \quad (4.91)$$

One then has

$$\begin{aligned} \langle \varphi_i \rangle &= \int d\varphi P_{\text{eq}}(\varphi) \varphi_i = \varepsilon_i \langle \varphi_i \rangle \\ G_{ij}(t) &\equiv \langle \varphi_i(t) \varphi_j(0) \rangle = \int d\varphi \int d\varphi' \varphi_i \varphi'_j P(\varphi, t | \varphi', 0) P_{\text{eq}}(\varphi') = \varepsilon_i \varepsilon_j G_{ji}(t). \end{aligned} \quad (4.92)$$

Thus, as a matrix,  $G(t) = \varepsilon G^t(t) \varepsilon$ .

The conditions under which detailed balance holds are<sup>10</sup>

$$\begin{aligned} W(\varphi | \varphi') P_{\text{eq}}(\varphi') &= W(\varepsilon\varphi' | \varepsilon\varphi) P_{\text{eq}}(\varphi) \\ \left[ A_i(\varphi) + \varepsilon_i A_i(\varepsilon\varphi) \right] P_{\text{eq}}(\varphi) &= \frac{\partial}{\partial \varphi_j} \left[ B_{ij}(\varphi) P_{\text{eq}}(\varphi) \right] \\ \varepsilon_i \varepsilon_j B_{ij}(\varepsilon\varphi) &= B_{ij}(\varphi) \quad (\text{no sum on } i \text{ and } j). \end{aligned} \quad (4.93)$$

### Detailed balance for the Fokker-Planck equation

It is useful to define the *reversible* and *irreversible drift* as

$$\begin{aligned} R_i(\varphi) &\equiv \frac{1}{2} \left[ A_i(\varphi) + \varepsilon_i A_i(\varepsilon\varphi) \right] \\ I_i(\varphi) &\equiv \frac{1}{2} \left[ A_i(\varphi) - \varepsilon_i A_i(\varepsilon\varphi) \right]. \end{aligned} \quad (4.94)$$

Then we may subtract

$$\partial_i \left[ \varepsilon_i A_i(\varepsilon\varphi) P_{\text{eq}}(\varphi) \right] - \frac{1}{2} \partial_i \partial_j \left[ \varepsilon_i \varepsilon_j B_{ij}(\varepsilon\varphi) P_{\text{eq}}(\varphi) \right]$$

from

$$\partial_i \left[ A_i(\varphi) P_{\text{eq}}(\varphi) \right] - \frac{1}{2} \partial_i \partial_j \left[ B_{ij}(\varphi) P_{\text{eq}}(\varphi) \right]$$

to obtain

$$\sum_i \frac{\partial}{\partial \varphi_i} \left[ I_i(\varphi) P_{\text{eq}}(\varphi) \right] = 0 \quad \Rightarrow \quad \sum_i \left\{ \frac{\partial I_i(\varphi)}{\partial \varphi_i} + I_i(\varphi) \frac{\partial \ln P_{\text{eq}}(\varphi)}{\partial \varphi_i} \right\} = 0. \quad (4.95)$$

We may now write the second of Eqn. 4.93 as

$$R_i(\varphi) = \frac{1}{2} \partial_j B_{ij}(\varphi) + \frac{1}{2} B_{ij}(\varphi) \partial_j \ln P_{\text{eq}}(\varphi), \quad (4.96)$$

or, assuming the matrix  $B$  is invertible,

$$\partial_k \ln P_{\text{eq}}(\varphi) = 2 B_{ki}^{-1} \left( R_i - \frac{1}{2} \partial_j B_{ij} \right) \equiv Z_k(\varphi). \quad (4.97)$$

Since the LHS above is a gradient, the condition that  $P_{\text{eq}}(\varphi)$  exists is tantamount to

$$\frac{\partial Z_i}{\partial \varphi_j} = \frac{\partial Z_j}{\partial \varphi_i} \quad (4.98)$$

for all  $i$  and  $j$ . If this is the case, then we have

$$P_{\text{eq}}(\varphi) = \exp \int_{\varphi'}^{\varphi} d\varphi' \cdot \mathbf{Z}(\varphi'). \quad (4.99)$$

Because of the condition 4.98, the integral on the RHS may be taken along any path. The constant associated with the undetermined lower limit of integration is set by overall normalization.

<sup>10</sup>See Gardiner, §6.3.5.

### Brownian motion in a local potential

Recall that the Brownian motion problem may be written as two coupled first order differential equations,

$$\begin{aligned} dx &= v dt \\ dv &= - \left[ \frac{1}{m} U'(x) + \gamma v \right] dt + \sqrt{\Gamma} dW(t), \end{aligned} \quad (4.100)$$

where  $\Gamma = 2\gamma k_B T/m = 2\gamma^2 D$ , and where  $W(t)$  is a Wiener process. The first of these is an ODE and the second an SDE. Viewed as a multicomponent SDE with

$$\varphi = \begin{pmatrix} x \\ v \end{pmatrix}, \quad A_i(\varphi) = \begin{pmatrix} v \\ -\frac{U'(x)}{m} - \gamma v \end{pmatrix}, \quad B_{ij}(\varphi) = \begin{pmatrix} 0 & 0 \\ 0 & \frac{2\gamma k_B T}{m} \end{pmatrix}. \quad (4.101)$$

We have already derived in Eqn. 4.77 the associated Fokker-Planck equation for  $P(x, v, t)$ .

The time reversal eigenvalues are  $\varepsilon_1 = +1$  for  $x$  and  $\varepsilon_2 = -1$  for  $v$ . We then have

$$\mathbf{R}(\varphi) = \begin{pmatrix} 0 \\ -\gamma v \end{pmatrix}, \quad \mathbf{I}(\varphi) = \begin{pmatrix} v \\ -\frac{U'(x)}{m} \end{pmatrix}. \quad (4.102)$$

As the  $B$  matrix is not invertible, we appeal to Eqn. 4.96. The upper component vanishes, and the lower component yields

$$-\gamma v = \frac{\gamma k_B T}{m} \frac{\partial \ln P_{\text{eq}}}{\partial v}, \quad (4.103)$$

which says  $P_{\text{eq}}(x, v) = F(x) \exp(-mv^2/2k_B T)$ . To find  $F(x)$ , we use Eqn. 4.95, which says

$$\begin{aligned} 0 &= \overbrace{\frac{\partial I_1}{\partial x}}^0 + \overbrace{\frac{\partial I_2}{\partial v}}^0 + I_1 \frac{\partial \ln P_{\text{eq}}}{\partial x} + I_2 \frac{\partial \ln P_{\text{eq}}}{\partial v} \\ &= v \frac{\partial \ln F}{\partial x} - \frac{U'(x)}{m} \left( -\frac{mv}{k_B T} \right) \Rightarrow F(x) = C e^{-U(x)/k_B T}. \end{aligned} \quad (4.104)$$

Thus,

$$P_{\text{eq}}(x, v) = C e^{-mv^2/2k_B T} e^{-U(x)/k_B T}. \quad (4.105)$$

### 4.2.8 Multicomponent Ornstein-Uhlenbeck process

In §3.4.3 we considered the case of coupled SDEs,

$$d\varphi_i = A_i(\varphi) dt + \beta_{ij}(\varphi) dW_j(t), \quad (4.106)$$

where  $\langle W_i(t) W_j(t') \rangle = \delta_{ij} \min(t, t')$ . We showed in §3.4.3 that such a multicomponent SDE leads to the Fokker-Planck equation

$$\frac{\partial P}{\partial t} = -\frac{\partial}{\partial \varphi_i} (A_i P) + \frac{1}{2} \frac{\partial^2}{\partial \varphi_i \partial \varphi_j} (B_{ij} P), \quad (4.107)$$

where  $B = \beta\beta^t$ , i.e.  $B_{ij} = \sum_k \beta_{ik}\beta_{jk}$ .

Now consider such a process with

$$A_i(\varphi) = A_{ij} \varphi_j \quad , \quad B_{ij}(\varphi) = B_{ij} \quad , \quad (4.108)$$

where  $A_{ij}$  and  $B_{ij}$  are independent of  $\varphi$ . The detailed balance conditions are written as  $\varepsilon B \varepsilon = B$ , and

$$(A + \varepsilon A \varepsilon) \varphi = B \nabla \ln P_{\text{eq}}(\varphi). \quad (4.109)$$

This equation says that  $P_{\text{eq}}(\varphi)$  must be a Gaussian, which we write as

$$P_{\text{eq}}(\varphi) = P_{\text{eq}}(0) \exp\left[-\frac{1}{2} \varphi_i M_{ij}^{-1} \varphi_j\right], \quad (4.110)$$

Obviously we can take  $M^{-1}$  to be symmetric, since any antisymmetric part of  $M^{-1}$  is projected out in the expression  $\varphi_i M_{ij}^{-1} \varphi_j$ . Thus  $M$  is also symmetric. Substituting this solution into the stationary Fokker-Planck equation  $\partial_i [A_{ij} \varphi_j P_{\text{eq}}] = \frac{1}{2} \partial_i \partial_j (B_{ij} P_{\text{eq}})$  yields

$$\text{Tr} A + \frac{1}{2} \text{Tr} (B M^{-1}) = \varphi_i \left[ M^{-1} A + \frac{1}{2} M^{-1} B M^{-1} \right]_{ij} \varphi_j = 0. \quad (4.111)$$

This must be satisfied for all  $\varphi$ , hence both the LHS and RHS of this equation must vanish separately. This entails

$$A + M A^t M^{-1} + B M^{-1} = 0. \quad (4.112)$$

We now invoke the detailed balance condition of Eqn. 4.109, which says

$$A + \varepsilon A \varepsilon + B M^{-1} = 0. \quad (4.113)$$

Combining this with our previous result, we conclude

$$\varepsilon A M = (A M)^t \varepsilon, \quad (4.114)$$

which are known as the *Onsager conditions*. If we define the phenomenological force

$$\mathbf{F} = \nabla \ln P_{\text{eq}} = -M^{-1} \varphi, \quad (4.115)$$

then we have

$$\frac{d\langle \varphi \rangle}{dt} = A \langle \varphi \rangle = -A M \mathbf{F}, \quad (4.116)$$

and defining  $L = -A M$  which relates the *fluxes*  $\mathbf{J} = \langle \dot{\varphi} \rangle$  to the *forces*  $\mathbf{F}$ , viz.  $J_i = L_{ik} F_k$ , we have the celebrated *Onsager relations*,  $\varepsilon L \varepsilon = L^t$ . A more general formulation, allowing for the presence of a magnetic field, is

$$L_{ik}(\mathbf{B}) = \varepsilon_i \varepsilon_k L_{ki}(-\mathbf{B}). \quad (4.117)$$

We shall meet up with the Onsager relations again when we study the Boltzmann equation.

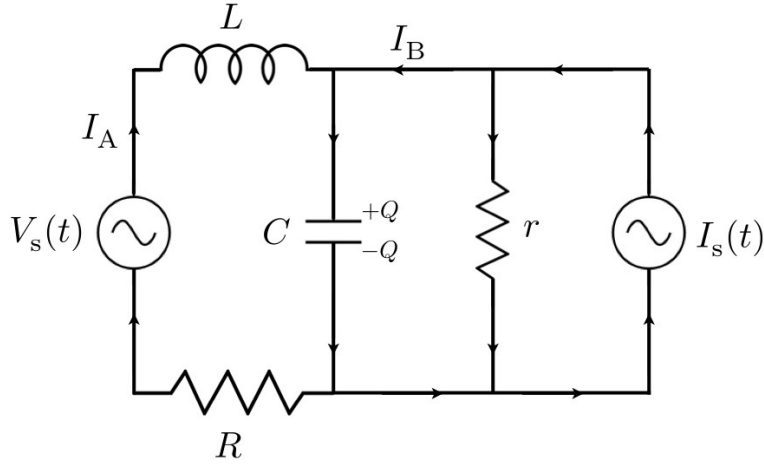

Figure 4.2: Electrical circuit containing a fluctuating voltage source  $V_s(t)$  and a fluctuating current source  $I_s(t)$ .

#### 4.2.9 Nyquist's theorem

Consider the electrical circuit in Fig. 4.2. Kirchoff's laws say that the current flowing through the resistor  $r$  is  $I_S - I_B$ , and that

$$(I_S - I_B) r = \frac{Q}{C} = V_S - L \frac{dI_A}{dt} - RI_A \quad (4.118)$$

and

$$\frac{dQ}{dt} = I_A + I_B. \quad (4.119)$$

Thus, we have the coupled ODEs for  $Q$  and  $I_A$ ,

$$\frac{dQ}{dt} = I_A - \frac{Q}{rC} + I_S(t) \quad (4.120)$$

$$\frac{dI_A}{dt} = -\frac{RI_A}{L} - \frac{Q}{LC} + \frac{V_S(t)}{L}.$$

If we assume  $V_S(t)$  and  $I_S(t)$  are fluctuating sources each described by a Wiener process, we may write

$$V_S(t) dt = \sqrt{\Gamma_V} dW_V(t) \quad , \quad I_S(t) dt = \sqrt{\Gamma_I} dW_I(t). \quad (4.121)$$

Then

$$\begin{aligned} dQ &= \left( -\frac{Q}{rC} + I_A \right) dt + \sqrt{\Gamma_I} dW_I(t) \\ dI_A &= -\left( \frac{Q}{LC} + \frac{RI_A}{L} \right) dt + \frac{1}{L} \sqrt{\Gamma_V} dW_V(t). \end{aligned} \quad (4.122)$$

We now see that Eqn. 4.122 describes a two component Ornstein-Uhlenbeck process, with  $\varphi^t = (Q, I_A)$ , and

$$A_{ij} = - \begin{pmatrix} 1/rC & -1 \\ 1/LC & R/L \end{pmatrix} \quad , \quad B_{ij} = \begin{pmatrix} \Gamma_I & 0 \\ 0 & \Gamma_V/L^2 \end{pmatrix} \quad . \quad (4.123)$$

The  $\varepsilon$  matrix for this problem is  $\varepsilon = \begin{pmatrix} 1 & 0 \\ 0 & -1 \end{pmatrix}$  since charge is even and current odd under time reversal. Thus,

$$A + \varepsilon A \varepsilon = - \begin{pmatrix} 2/rC & 0 \\ 0 & 2R/L \end{pmatrix} = -BM^{-1} \quad , \quad (4.124)$$

from which we may obtain  $M^{-1}$  and then

$$M = \begin{pmatrix} \Gamma_I rC/2 & 0 \\ 0 & \Gamma_V/2LR \end{pmatrix} \quad . \quad (4.125)$$

The equilibrium distribution is then

$$P_{\text{eq}}(Q, I_A) = \mathcal{N} \exp \left\{ - \frac{Q^2}{rC\Gamma_I} - \frac{RLI_A^2}{\Gamma_V} \right\} \quad . \quad (4.126)$$

We now demand that equipartition hold, *i.e.*

$$\left\langle \frac{Q^2}{2C} \right\rangle = \left\langle \frac{LI_A^2}{2} \right\rangle = \frac{1}{2} k_B T \quad , \quad (4.127)$$

which fixes

$$\Gamma_V = 2Rk_B T \quad , \quad \Gamma_I = 2k_B T/r \quad . \quad (4.128)$$

Therefore, the current and voltage fluctuations are given by

$$\langle V_S(0) V_S(t) \rangle = 2k_B TR \delta(t) \quad , \quad \langle I_S(0) I_S(t) \rangle = \frac{2k_B T}{r} \delta(t) \quad , \quad \langle V_S(0) I_S(t) \rangle = 0 \quad . \quad (4.129)$$

### 4.3 Master Equation

In §2.6.3 we showed that the differential Chapman-Kolmogorov equation with only jump processes yielded the Master equation,

$$\frac{\partial P(\mathbf{x}, t | \mathbf{x}', t')}{\partial t} = \int d\mathbf{y} \left[ W(\mathbf{x} | \mathbf{y}, t) P(\mathbf{y}, t | \mathbf{x}', t') - W(\mathbf{y} | \mathbf{x}, t) P(\mathbf{x}, t | \mathbf{x}', t') \right] \quad . \quad (4.130)$$

Here  $W(\mathbf{x} | \mathbf{y}, t)$  is the rate density of transitions from  $\mathbf{y}$  to  $\mathbf{x}$  at time  $t$ , and has dimensions  $T^{-1}L^{-d}$ . On a discrete state space, we have

$$\frac{\partial P(\mathbf{n}, t | \mathbf{n}', t')}{\partial t} = \sum_m \left[ W(\mathbf{n} | \mathbf{m}, t) P(\mathbf{m}, t | \mathbf{n}', t') - W(\mathbf{m} | \mathbf{n}, t) P(\mathbf{n}, t | \mathbf{n}', t') \right] \quad , \quad (4.131)$$

where  $W(\mathbf{n} | \mathbf{m}, t)$  is the rate of transitions from  $\mathbf{m}$  to  $\mathbf{n}$  at time  $t$ , with dimensions  $T^{-1}$ .

### 4.3.1 Birth-death processes

The simplest case is that of one variable  $n$ , which represents the number of individuals in a population. Thus  $n \geq 0$  and  $P(n, t | n', t') = 0$  if  $n < 0$  or  $n' < 0$ . If we assume that births and deaths happen individually and at with a time-independent rate, then we may write

$$W(n | m, t) = t^+(m) \delta_{n, m+1} + t^-(m) \delta_{n, m-1} . \quad (4.132)$$

Here  $t^+(m)$  is the rate for  $m \rightarrow m + 1$ , and  $t^-(m)$  is the rate for  $m \rightarrow m - 1$ . We require  $t^-(0) = 0$ , since the dying rate for an entirely dead population must be zero<sup>11</sup>. We then have the Master equation

$$\frac{\partial P(n, t | n_0, t_0)}{\partial t} = t^+(n-1) P(n-1, t | n_0, t_0) + t^-(n+1) P(n+1, t | n_0, t_0) - [t^+(n) + t^-(n)] P(n, t | n_0, t_0) . \quad (4.133)$$

This may be written in the form

$$\frac{\partial P(n, t | n_0, t_0)}{\partial t} + \Delta J(n, t | n_0, t_0) = 0 , \quad (4.134)$$

where the lattice current operator on the link  $(n, n + 1)$  is

$$J(n, t | n_0, t_0) = t^+(n) P(n, t | n_0, t_0) - t^-(n+1) P(n+1, t | n_0, t_0) . \quad (4.135)$$

The lattice derivative  $\Delta$  is defined by

$$\Delta f(n) = f(n) - f(n-1) , \quad (4.136)$$

for any lattice function  $f(n)$ . One then has

$$\frac{d\langle n \rangle_t}{dt} = \sum_{n=0}^{\infty} [t^+(n) - t^-(n)] P(n, t | n_0, t_0) = \langle t^+(n) \rangle_t - \langle t^-(n) \rangle . \quad (4.137)$$

#### Steady state solution

We now seek a steady state solution  $P_{\text{eq}}(n)$ , as we did in the case of the Fokker-Planck equation. This entails  $\Delta_n J(n) = 0$ , where we suppress the initial conditions  $(n_0, t_0)$ . Now  $J(-1) = 0$  because  $t^-(0) = 0$  and  $P(-1) = 0$ , hence  $0 = J(0) - J(-1)$  entails  $J(0) = 0$ , and since  $0 = \Delta_n J(n)$  we have  $J(n) = 0$  for all  $n \geq 0$ . Therefore

$$P_{\text{eq}}(j+1) = \frac{t^+(j)}{t^-(j+1)} P_{\text{eq}}(j) , \quad (4.138)$$

which means

$$P_{\text{eq}}(n) = P_{\text{eq}}(0) \prod_{j=1}^n \frac{t^+(j-1)}{t^-(j)} . \quad (4.139)$$

---

<sup>11</sup>We neglect here the important possibility of zombies.



### 4.3.2 Examples: reaction kinetics

#### First example

Consider the example in Gardiner §11.1.2, which is the reaction



We assume the concentration  $[A] = a$  is fixed, and denote the number of  $X$  reactants to be  $n$ . The rates are  $t^-(n) = k_2 n$  and  $t^+(n) = k_1 a$ , hence we have the Master equation

$$\partial_t P(n, t) = k_2(n+1)P(n+1, t) + k_1 a P(n-1, t) - (k_2 n + k_1 a)P(n, t) , \quad (4.141)$$

with  $P(-1, t) \equiv 0$ . We solve this using the generating function formalism, defining

$$\tilde{P}(z, t) = \sum_{n=0}^{\infty} z^n P(n, t) . \quad (4.142)$$

Note that  $\tilde{P}(1, t) = \sum_{n=0}^{\infty} P(n, t) = 1$  by normalization. Multiplying both sides of Eqn. 4.141 by  $z^n$  and then summing from  $n = 0$  to  $n = \infty$ , we obtain

$$\begin{aligned} \partial_t \tilde{P}(z, t) &= k_1 a \overbrace{\sum_{n=0}^{\infty} P(n-1, t) z^n}^{zP(z, t)} - k_1 a \overbrace{\sum_{n=0}^{\infty} P(n, t) z^n}^{P(z, t)} + k_2 \overbrace{\sum_{n=0}^{\infty} (n+1) P(n+1, t) z^n}^{\partial_z P(z, t)} - k_2 \overbrace{\sum_{n=0}^{\infty} n P(n, t) z^n}^{z \partial_z P(z, t)} \\ &= (z-1) \left\{ k_1 a \tilde{P}(z, t) - k_2 \partial_z \tilde{P}(z, t) \right\} . \end{aligned} \quad (4.143)$$

We now define the function  $\tilde{Q}(z, t)$  via

$$\tilde{P}(z, t) = e^{k_1 a z / k_2} \tilde{Q}(z, t) , \quad (4.144)$$

so that

$$\partial_t \tilde{Q} + k_2(z-1) \partial_z \tilde{Q} = 0 , \quad (4.145)$$

and defining  $w = -\ln(1-z)$ , this is recast as  $\partial_t \tilde{Q} - k_2 \partial_w \tilde{Q} = 0$ , whose solution is

$$\tilde{Q}(z, t) = F(w + k_2 t) , \quad (4.146)$$

where  $F$  is an arbitrary function of its argument. To determine the function  $F(w)$ , we invoke our initial conditions,

$$\tilde{Q}(z, 0) = e^{-k_1 a z / k_2} \tilde{P}(z, 0) = F(w) . \quad (4.147)$$

We then have

$$F(w) = \exp \left\{ -\frac{k_1 a}{k_2} (1 - e^{-w}) \right\} \tilde{P}(1 - e^{-w}, 0) , \quad (4.148)$$

and hence

$$\tilde{P}(z, t) = \exp \left\{ -\frac{k_1 a}{k_2} (1-z)(1-e^{-k_2 t}) \right\} \tilde{P}(1 - (1-z)e^{-k_2 t}, 0). \quad (4.149)$$

We may then obtain  $P(n, t)$  via contour integration, *i.e.* by extracting the coefficient of  $z^n$  in the above expression:

$$P(n, t) = \frac{1}{2\pi i} \oint_{|z|=1} \frac{dz}{z^{n+1}} \tilde{P}(z, t). \quad (4.150)$$

Note that setting  $t = 0$  in Eqn. 4.149 yields the identity  $\tilde{P}(z, 0) = \tilde{P}(z, 0)$ . As  $t \rightarrow \infty$ , we have the steady state result

$$\tilde{P}(z, \infty) = e^{k_1 a(z-1)/k_2} \quad \Rightarrow \quad P(n, \infty) = \frac{\lambda^n}{n!} e^{-\lambda}, \quad (4.151)$$

where  $\lambda = k_1 a/k_2$ , which is a Poisson distribution. Indeed, suppose we start at  $t = 0$  with the Poisson distribution  $P(n, 0) = e^{-\alpha_0} \alpha_0^n / n!$ . Then  $\tilde{P}(z, 0) = \exp[\alpha_0(z-1)]$ , and Eqn. 4.149 gives

$$\tilde{P}(z, t) = \exp \left\{ -\frac{k_1 a}{k_2} (1-z)(1-e^{-k_2 t}) \right\} \exp \left\{ -\alpha_0(1-z)e^{-k_2 t} \right\} = e^{\alpha(t)(z-1)}, \quad (4.152)$$

where

$$\alpha(t) = \alpha_0 e^{-k_2 t} + \frac{k_1}{k_2} a (1 - e^{-k_2 t}). \quad (4.153)$$

Thus,  $\alpha(0) = \alpha_0$  and  $\alpha(\infty) = k_1 a/k_2 = \lambda$ . The distribution is Poisson all along, with a time evolving Poisson parameter  $\alpha(t)$ . The situation is somewhat reminiscent of the case of updating conjugate Bayesian priors, where the prior distribution was matched with the likelihood function so that the updated prior retains the same functional form.

If we start instead with  $P(n, 0) = \delta_{n, n_0}$ , then we have  $\tilde{P}(z, 0) = z^{n_0}$ , and

$$\tilde{P}(z, t) = \exp \left\{ -\frac{k_1 a}{k_2} (1-z)(1-e^{-k_2 t}) \right\} \left( 1 - (1-z)e^{-k_2 t} \right)^{n_0}. \quad (4.154)$$

We then have

$$\begin{aligned} \langle n(t) \rangle &= \left. \frac{\partial \tilde{P}(z, t)}{\partial z} \right|_{z=1} = \frac{k_1 a}{k_2} (1 - e^{-k_2 t}) + n_0 e^{-k_2 t} \\ \langle n^2(t) \rangle &= \left( \left. \frac{\partial^2 \tilde{P}(z, t)}{\partial z^2} + \frac{\partial \tilde{P}(z, t)}{\partial z} \right) \right|_{z=1} = \langle n(t) \rangle^2 + \langle n(t) \rangle - n_0 e^{-2k_2 t} \\ \text{Var}[n(t)] &= \left( \frac{k_1 a}{k_2} + n_0 e^{-k_2 t} \right) (1 - e^{-k_2 t}). \end{aligned} \quad (4.155)$$

## Second example

Gardiner next considers the reactions

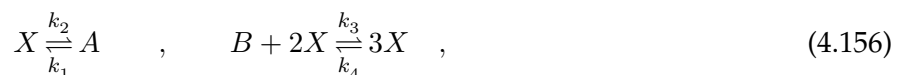

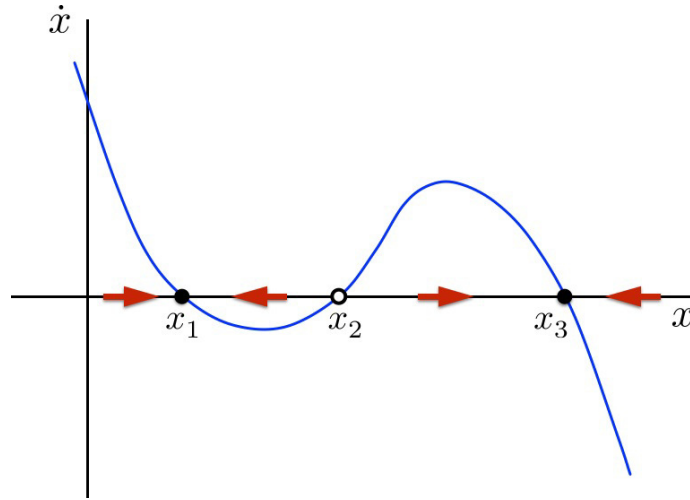

Figure 4.3: Geometric interpretation of the ODE in Eqn. 4.160.

for which we have

$$\begin{aligned} t^+(n) &= k_1 a + k_3 b n(n-1) \\ t^-(n) &= k_2 n + k_4 n(n-1)(n-2). \end{aligned} \quad (4.157)$$

The reason here is that for the second equation to proceed to the left, we need to select three  $X$  molecules to take part in the reaction, and there are  $n(n-1)(n-2)$  ordered triples  $(i, j, k)$ . Now Eqn. 4.137 gives

$$\frac{d\langle n \rangle}{dt} = k_1 a + k_3 \langle n(n-1) \rangle - k_2 \langle n \rangle - k_4 \langle n(n-1)(n-2) \rangle. \quad (4.158)$$

For a Poisson distribution  $P_n = e^{-\lambda} \lambda^n / n!$ , it is easy to see that

$$\langle n(n-1) \cdots (n-k+1) \rangle = \langle n \rangle^k \quad (\text{Poisson}). \quad (4.159)$$

Suppose the distribution  $P(n, t)$  is Poissonian for all  $t$ . This is not necessarily the case, but we assume it to be so for the purposes of approximation. Then the above equation closes, and with  $x = \langle n \rangle$ , we have

$$\begin{aligned} \frac{dx}{dt} &= -k_4 x^3 + k_3 x^2 - k_2 x + k_1 a \\ &= -k_4 (x - x_1)(x - x_2)(x - x_3), \end{aligned} \quad (4.160)$$

where  $x_{1,2,3}$  are the three roots of the cubic on the RHS of the top equation. Since the coefficients of this equation are real numbers, the roots are either real or come in complex conjugate pairs. We know that the product of the roots is  $x_1 x_2 x_3 = k_1 a / k_4$  and that the sum is  $x_1 + x_2 + x_3 = k_3 / k_4$ , both of which are positive. Clearly when  $x$  is real and negative, all terms in the cubic are of the same sign, hence there can be no real roots with  $x < 0$ . We assume three real positive roots with  $x_1 < x_2 < x_3$ .

Further examining Eqn. 4.160, we see that  $x_1$  and  $x_3$  are stable fixed points and that  $x_2$  is an unstable fixed point of this one-dimensional dynamical system. Thus, there are two possible stable equilibria. If

$x(0) < x_2$  the flow will be toward  $x_1$ , while if  $x(0) > x_2$  the flow will be toward  $x_3$ . We can integrate Eqn. 4.160 using the method of partial fractions. First, we write

$$\frac{1}{(x-x_1)(x-x_2)(x-x_3)} = \frac{A_1}{x-x_1} + \frac{A_2}{x-x_2} + \frac{A_3}{x-x_3}, \quad (4.161)$$

with  $(x-x_2)(x-x_3)A_1 + (x-x_1)(x-x_3)A_2 + (x-x_1)(x-x_2)A_3 = 1$ . This requires

$$\begin{aligned} 0 &= A_1 + A_2 + A_3 \\ 0 &= (x_2 + x_3)A_1 + (x_1 + x_3)A_2 + (x_1 + x_2)A_3 \\ 1 &= x_2x_3A_1 + x_1x_3A_2 + x_1x_2A_3 \end{aligned} \quad (4.162)$$

with solution

$$A_1 = \frac{1}{(x_2-x_1)(x_3-x_1)}, \quad A_2 = -\frac{1}{(x_2-x_1)(x_3-x_2)}, \quad A_3 = \frac{1}{(x_3-x_1)(x_3-x_2)}. \quad (4.163)$$

Thus, Eqn. 4.160 may be recast as

$$(x_3-x_2) d \ln(x-x_1) - (x_3-x_1) d \ln(x-x_2) + (x_2-x_1) d \ln(x-x_3) = -k_4(x_2-x_1)(x_3-x_1)(x_3-x_2) dt. \quad (4.164)$$

The solution is given in terms of  $t(x)$ :

$$\begin{aligned} t(x) &= \frac{1}{k_4(x_2-x_1)(x_3-x_1)} \ln\left(\frac{x_0-x_1}{x-x_1}\right) \\ &\quad - \frac{1}{k_4(x_2-x_1)(x_3-x_2)} \ln\left(\frac{x_0-x_2}{x-x_2}\right) + \frac{1}{k_4(x_3-x_1)(x_3-x_2)} \ln\left(\frac{x_0-x_2}{x-x_3}\right), \end{aligned} \quad (4.165)$$

where  $x_0 = x(0)$ .

Going back to Eqn. 4.139, we have that the steady state distribution is

$$P_{\text{eq}}(n) = P_{\text{eq}}(0) \prod_{j=1}^n \frac{t^+(j-1)}{t^-(j)} = P_{\text{eq}}(0) \prod_{j=1}^n \frac{k_1 a + k_3 b (j-1)(j-2)}{k_2 j + k_4 j(j-1)(j-2)}. \quad (4.166)$$

The product is maximized for when the last term with  $j = n$  is unity. If we call this value  $n^*$ , then  $n^*$  is a root of the equation

$$k_1 a + k_3 b (n-1)(n-2) = k_2 n + k_4 n(n-1)(n-2). \quad (4.167)$$

If  $n \gg 1$  and all the terms are roughly the same size, this equation becomes  $k_1 a + k_3 b n^2 = k_2 n + k_4 n^3$ , which is the same as setting the RHS of Eqn. 4.160 to zero in order to find a stationary solution.

### 4.3.3 Forward and reverse equations and boundary conditions

In §2.6.3 we discussed the forward and backward differential Chapman-Kolmogorov equations, from which, with  $A_\mu = 0$  and  $B_{\mu\nu} = 0$ , we obtain the forward and reverse Master equations,

$$\begin{aligned} \frac{\partial P(\mathbf{n}, t | \cdot)}{\partial t} &= \sum_{\mathbf{m}} \left\{ W(\mathbf{n} | \mathbf{m}, t) P(\mathbf{m}, t | \cdot) - W(\mathbf{m} | \mathbf{n}, t) P(\mathbf{n}, t | \cdot) \right\} \\ -\frac{\partial P(\cdot | \mathbf{n}, t)}{\partial t} &= \sum_{\mathbf{m}} W(\mathbf{m} | \mathbf{n}, t) \left\{ P(\cdot | \mathbf{m}, t) - P(\cdot | \mathbf{n}, t) \right\}, \end{aligned} \quad (4.168)$$

where we have suppressed the initial conditions in the forward equation and the final conditions in the backward equation. Consider the one-dimensional version, and take the transition rates to be

$$W(j' | j, t) = t^+(j) \delta_{j',j+1} + t^-(j) \delta_{j',j-1} \quad . \quad (4.169)$$

We may then write

$$\frac{\partial P(n, t | \cdot)}{\partial t} = \mathcal{L}P(n, t | \cdot) = \overbrace{\left\{ t^+(n-1) P(n-1, t | \cdot) - t^-(n) P(n, t | \cdot) \right\}}^{J(n-1, t | \cdot)} \quad (4.170)$$

$$- \frac{\partial P(\cdot | n, t)}{\partial t} = \tilde{\mathcal{L}}P(\cdot | n, t) = t^+(n) \overbrace{\left\{ P(\cdot | n+1, t) - P(\cdot | n, t) \right\}}^{K(\cdot | n+1, t)} - t^-(n) \overbrace{\left\{ P(\cdot | n, t) - P(\cdot | n-1, t) \right\}}^{K(\cdot | n, t)} \quad , \quad (4.171)$$

where we have defined the quantities  $J(n, t | \cdot)$  and  $K(\cdot | n, t)$ . Here  $(\mathcal{L}f)_n = \mathcal{L}_{nn'} f_{n'}$  and  $(\tilde{\mathcal{L}}f)_n = \tilde{\mathcal{L}}_{nn'} f_{n'}$ , where  $\mathcal{L}$  and  $\tilde{\mathcal{L}}$  are matrices, viz.

$$\mathcal{L}_{nn'} = t^+(n') \delta_{n',n-1} + t^-(n') \delta_{n',n+1} - t^+(n') \delta_{n',n} - t^-(n') \delta_{n',n} \quad (4.172)$$

$$\tilde{\mathcal{L}}_{nn'} = t^+(n) \delta_{n',n+1} + t^-(n) \delta_{n',n-1} - t^+(n) \delta_{n',n} - t^-(n) \delta_{n',n} \quad .$$

Clearly  $\tilde{\mathcal{L}}_{nn'} = \mathcal{L}_{n'n}$ , hence  $\tilde{\mathcal{L}} = \mathcal{L}^t$ , the matrix transpose, if we can neglect boundary terms. For  $n, n' \in \mathbb{Z}$ , we could specify  $P(\pm\infty, t | \cdot) = P(\cdot | \pm\infty, t) = 0$ .

Consider now a birth-death process where we focus on a finite interval  $n \in \{a, \dots, b\}$ . Define the inner product

$$\langle g | \mathcal{O} | f \rangle = \sum_{n=a}^b g(n) (\mathcal{O}f)(n) \quad . \quad (4.173)$$

One then has

$$\langle g | \mathcal{L} | f \rangle - \langle f | \tilde{\mathcal{L}} | g \rangle = t^-(b+1) f(b+1) g(b) - t^+(b) f(b) g(b+1) \\ + t^+(a-1) f(a-1) g(a) - t^-(a) f(a) g(a-1) \quad . \quad (4.174)$$

Thus, if  $f(a-1) = g(a-1) = f(b+1) = g(b+1) = 0$ , we have  $\tilde{\mathcal{L}} = \mathcal{L}^t = \mathcal{L}^\dagger$ , the adjoint. In the suppressed initial and final conditions, we always assume the particle coordinate  $n$  lies within the interval.

We now must specify appropriate boundary conditions on our interval. These conditions depend on whether we are invoking the forward or backward Master equation:

- **Forward equation** : For reflecting boundaries, we set  $t^-(a) = 0$  and  $t^+(b) = 0$ , assuring that a particle starting from inside the region can never exit. We also specify  $P(a-1, t | \cdot) = 0$  and

$P(b+1, t | \cdot) = 0$  so that no particles can enter from the outside. This is equivalent to specifying that the boundary currents vanish, *i.e.*  $J(a-1, t | \cdot) = 0$  and  $J(b, t | \cdot) = 0$ , respectively. For absorbing boundaries, we choose  $t^+(a-1) = 0$  and  $t^-(b+1) = 0$ , which assures that a particle which exits the region can never reenter. This is equivalent to demanding  $P(a-1, t | \cdot) = 0$  and  $P(b+1, t | \cdot) = 0$ , respectively.

- **Backward equation** : From Eqn. 4.171, it is clear that the reflecting conditions  $t^-(a) = 0$  and  $t^+(b) = 0$  are equivalent to  $K(\cdot | a, t) = 0$  and  $K(\cdot | b+1, t) = 0$ , where these functions. Neither of the quantities in the absorbing conditions  $t^+(a-1) = 0$  and  $t^-(b+1) = 0$  enter in the backward Master equation. The effect of these conditions on the data outside the interval is to preserve  $P(\cdot | a-1, t) = 0$  and  $P(\cdot | b+1, t) = 0$ , respectively.

The situation is summarized in Tab. 4.3.3 below.

equation	boundary	conditions		equivalent conditions	
		reflecting	absorbing	reflecting	absorbing
FORWARD	left	$t^-(a) = 0$	$t^+(a-1) = 0$	$J(a-1, t   \cdot) = 0$	$P(a-1, t   \cdot)$
	right	$t^+(b) = 0$	$t^-(b+1) = 0$	$J(b, t   \cdot) = 0$	$P(b+1, t   \cdot)$
BACKWARD	left	$t^-(a) = 0$	$t^+(a-1) = 0$	$K(\cdot   a, t) = 0$	$P(\cdot   a-1, t)$
	right	$t^+(b) = 0$	$t^-(b+1) = 0$	$K(\cdot   b+1, t) = 0$	$P(\cdot   b+1, t)$

Table 4.1: Absorbing and reflecting boundary conditions for the Master equation on the interval  $\{a, \dots, b\}$ .

#### 4.3.4 First passage times

The treatment of first passage times within the Master equation follows that for the Fokker-Planck equation in §4.2.5. If our discrete particle starts at  $n$  at time  $t_0 = 0$ , the probability that it lies within the interval  $\{a, \dots, b\}$  at some later time  $t$  is

$$G(n, t) = \sum_{n'=a}^b P(n', t | n, 0) = \sum_{n'=a}^b P(n', 0 | n, -t) \quad , \quad (4.175)$$

and therefore  $-\partial_t G(n, t) dt$  is the probability that the particle exits the interval within the time interval  $[t, t + dt]$ . Therefore the average first passage time out of the interval, starting at  $n$  at time  $t_0 = 0$ , is

$$T(n) = \int_0^\infty dt t \left( -\frac{\partial G(n, t)}{\partial t} \right) = \int_0^\infty dt G(n, t) \quad . \quad (4.176)$$

Applying  $\tilde{\mathcal{L}}$ , we obtain

$$\tilde{\mathcal{L}}T(n) = t^+(n) \left\{ T(n+1) - T(n) \right\} - t^-(n) \left\{ T(n) - T(n-1) \right\} = -1 \quad . \quad (4.177)$$

Let  $a$  be a reflecting barrier and  $b$  be absorbing. Since  $t^-(a) = 0$  we are free to set  $T(a-1) = T(a)$ . At the right boundary we have  $T(b+1) = 0$ , because a particle starting at  $b+1$  is already outside the interval. Eqn. 4.177 may be written

$$t^+(n) \Delta T(n) - t^-(n) \Delta T(n-1) = -1 \quad , \quad (4.178)$$

with  $\Delta T(n) \equiv T(n+1) - T(n)$ . Now define the function

$$\phi(n) = \prod_{j=a+1}^n \frac{t^-(j)}{t^+(j)} \quad , \quad (4.179)$$

with  $\phi(a) \equiv 1$ . This satisfies  $\phi(n)/\phi(n-1) = t^-(n)/t^+(n)$ , and therefore Eqn. 4.178 may be recast as

$$\frac{\Delta T(n)}{\phi(n)} = \frac{\Delta T(n-1)}{\phi(n-1)} - \frac{1}{t^+(n) \phi(n)} \quad . \quad (4.180)$$

Since  $\Delta T(a) = -1/t^+(a)$  from Eqn. 4.177, the first term on the RHS above vanishes for  $n = a$ . We then have

$$\Delta T(n) = -\phi(n) \sum_{j=a}^n \frac{1}{t^+(j) \phi(j)} \quad , \quad (4.181)$$

and therefore, working backward from  $T(b+1) = 0$ , we have

$$T(n) = \sum_{k=n}^b \phi(k) \sum_{j=a}^k \frac{1}{t^+(j) \phi(j)} \quad (a \text{ reflecting, } b \text{ absorbing}). \quad (4.182)$$

One may also derive

$$T(n) = \sum_{k=a}^n \phi(k) \sum_{j=k}^b \frac{1}{t^+(j) \phi(j)} \quad (a \text{ absorbing, } b \text{ reflecting}). \quad (4.183)$$

### Example

Suppose  $a = 0$  is reflecting and  $b = N - 1$  is absorbing, and furthermore suppose that  $t^\pm(n) = t^\pm$  are site-independent. Then  $\phi(n) = r^{-n}$ , where  $r \equiv t^+/t^-$ . The mean escape time starting from site  $n$  is

$$\begin{aligned} T(n) &= \frac{1}{t^+} \sum_{k=n}^{N-1} r^{-k} \sum_{j=0}^k r^j \\ &= \frac{1}{(r-1)^2 t^+} \left\{ (N-n)(r-1) + r^{-N} - r^{-n} \right\} \quad . \end{aligned} \quad (4.184)$$

If  $t^+ = t^-$ , so the walk is unbiased, then  $r = 1$ . We can then evaluate by taking  $r = 1 + \varepsilon$  with  $\varepsilon \rightarrow 0$ , or, more easily, by evaluating the sum in the first line when  $r = 1$ . The result is

$$T(n) = \frac{1}{t^+} \left\{ \frac{1}{2}N(N-1) - \frac{1}{2}n(n+1) + N - n \right\} \quad (r = 1). \quad (4.185)$$

By taking an appropriate limit, we can compare with the Fokker-Planck result of Eqn. 4.61, which for an interval  $[a, b]$  with  $a = 0$  reflecting and  $b$  absorbing yields  $T(x) = (b^2 - x^2)/2D$ . Consider the Master equation,

$$\frac{\partial P(n, t)}{\partial t} = \beta \left[ P(n+1, t) + P(n-1, t) - 2P(n, t) \right] = \beta \frac{\partial^2 P}{\partial n^2} + \frac{1}{12}\beta \frac{\partial^4 P}{\partial n^4} + \dots, \quad (4.186)$$

where  $\beta = t^+ = t^-$ . Now define  $n \equiv Nx/b$ , and rescale both time  $t \equiv N\tau$  and hopping  $\beta \equiv N\gamma$ , resulting in

$$\frac{\partial P}{\partial \tau} = D \frac{\partial^2 P}{\partial x^2} + \frac{Db^2}{12N^2} \frac{\partial^4 P}{\partial x^4} + \dots, \quad (4.187)$$

where  $D = b^2\gamma$  is the diffusion constant. In the continuum limit,  $N \rightarrow \infty$  and we may drop all terms beyond the first on the RHS, yielding the familiar diffusion equation. Taking this limit, Eqn. 4.185 may be rewritten as  $T(x)/N = (N/2t^+b^2)(b^2 - x^2) = (b^2 - x^2)/2D$ , which agrees with the result of Eqn. 4.61.

### 4.3.5 From Master equation to Fokker-Planck

Let us start with the Master equation,

$$\frac{\partial P(\mathbf{x}, t)}{\partial t} = \int d\mathbf{x}' \left[ W(\mathbf{x} | \mathbf{x}') P(\mathbf{x}', t) - W(\mathbf{x}' | \mathbf{x}) P(\mathbf{x}, t) \right], \quad (4.188)$$

and define  $W(z | z_0) \equiv t(z - z_0 | z_0)$ , which rewrites the rate  $W(z | z_0)$  from  $z_0$  to  $z$  as a function of  $z_0$  and the distance  $z - z_0$  to  $z$ . Then the Master equation may be rewritten as

$$\frac{\partial P(\mathbf{x}, t)}{\partial t} = \int d\mathbf{y} \left[ t(\mathbf{y} | \mathbf{x} - \mathbf{y}) P(\mathbf{x} - \mathbf{y}, t) - t(\mathbf{y} | \mathbf{x}) P(\mathbf{x}, t) \right]. \quad (4.189)$$

Now expand  $t(\mathbf{y} | \mathbf{x} - \mathbf{y}) P(\mathbf{x} - \mathbf{y})$  as a power series in the jump distance  $\mathbf{y}$  to obtain<sup>12</sup>

$$\begin{aligned} \frac{\partial P(\mathbf{x}, t)}{\partial t} &= \int d\mathbf{y} \sum_{n=1}^{\infty} \frac{(-1)^n}{n!} y_{\alpha_1} \cdots y_{\alpha_n} \frac{\partial^n}{\partial x_{\alpha_1} \cdots \partial x_{\alpha_n}} \left[ t(\mathbf{y} | \mathbf{x}) P(\mathbf{x}, t) \right] \\ &= \sum_{n=1}^{\infty} \frac{(-1)^n}{n!} \frac{\partial^n}{\partial x_{\alpha_1} \cdots \partial x_{\alpha_n}} \left[ R^{\alpha_1 \cdots \alpha_n}(\mathbf{x}) P(\mathbf{x}, t) \right], \end{aligned} \quad (4.190)$$

where

$$R^{\alpha_1 \cdots \alpha_n}(\mathbf{x}) = \int d\mathbf{y} y_{\alpha_1} \cdots y_{\alpha_n} t(\mathbf{y} | \mathbf{x}). \quad (4.191)$$

<sup>12</sup>We only expand the second argument of  $t(\mathbf{y} | \mathbf{x} - \mathbf{y})$  in  $\mathbf{y}$ . We retain the full  $\mathbf{y}$ -dependence of the first argument.



For  $d = 1$  dimension, we may write

$$\frac{\partial P(x, t)}{\partial t} = \sum_{n=1}^{\infty} \frac{(-1)^n}{n!} \frac{\partial^n}{\partial x^n} \left[ R_n(x) P(x, t) \right] \quad , \quad R_n(x) \equiv \int dy y^n t(y | x) \quad . \quad (4.192)$$

This is known as the *Kramers-Moyal* expansion. If we truncate at order  $n = 2$ , we obtain the Fokker-Planck equation,

$$\frac{\partial P(x, t)}{\partial t} = -\frac{\partial}{\partial x} \left[ R_1(x) P(x, t) \right] + \frac{1}{2} \frac{\partial^2}{\partial x^2} \left[ R_2(x) P(x, t) \right] \quad . \quad (4.193)$$

The problem is that the FPE here is akin to a Procrustean bed. We have amputated the  $n > 2$  terms from the expansion without any justification at all, and we have no reason to expect this will end well. A more systematic approach was devised by N. G. van Kampen, and goes by the name of the *size expansion*. One assumes that there is a large quantity lurking about, which we call  $\Omega$ . Typically this can be the total system volume, or the total population in the case of an ecological or epidemiological model. One assumes that  $t(y | x)$  obeys a scaling form,

$$t(\Delta z | z_0) = \Omega \tau \left( \Delta z \left| \frac{z_0}{\Omega} \right. \right) \quad . \quad (4.194)$$

From the second of Eqn. 4.192, we then have

$$R_n(x) = \Omega \int dy y^n \tau \left( y \left| \frac{x}{\Omega} \right. \right) \equiv \Omega \tilde{R}_n(x/\Omega) \quad . \quad (4.195)$$

We now proceed by defining

$$x = \Omega \phi(t) + \sqrt{\Omega} \xi \quad , \quad (4.196)$$

where  $\phi(t)$  is an as-yet undetermined function of time, and  $\xi$  is to replace  $x$ , so that our independent variables are now  $(\xi, t)$ . We therefore have

$$R_n(x) = \Omega \tilde{R}_n(\phi(t) + \Omega^{-1/2} \xi) \quad . \quad (4.197)$$

Now we are set to derive a systematic expansion in inverse powers of  $\Omega$ . We define  $P(x, t) = \Pi(\xi, t)$ , and we note that  $dx = \Omega \dot{\phi} dt + \sqrt{\Omega} d\xi$ , hence  $d\xi|_x = -\sqrt{\Omega} \dot{\phi} dt$ , which means

$$\frac{\partial P(x, t)}{\partial t} = \frac{\partial \Pi(\xi, t)}{\partial t} - \sqrt{\Omega} \dot{\phi} \frac{\partial \Pi(\xi, t)}{\partial \xi} \quad . \quad (4.198)$$

We therefore have, from Eqn. 4.192,

$$\frac{\partial \Pi(\xi, t)}{\partial t} - \sqrt{\Omega} \dot{\phi} \frac{\partial \Pi}{\partial \xi} = \sum_{n=1}^{\infty} \frac{(-1)^n \Omega^{(2-n)/2}}{n!} \frac{\partial^n}{\partial \xi^n} \left[ \tilde{R}_n(\phi(t) + \Omega^{-1/2} \xi) \Pi(\xi, t) \right] \quad . \quad (4.199)$$

Further expanding  $\tilde{R}_n(\phi + \Omega^{-1/2} \xi)$  in powers of  $\Omega^{-1/2}$ , we obtain

$$\frac{\partial \Pi(\xi, t)}{\partial t} - \sqrt{\Omega} \dot{\phi} \frac{\partial \Pi}{\partial \xi} = \sum_{k=0}^{\infty} \sum_{n=1}^{\infty} \frac{(-1)^n \Omega^{(2-n-k)/2}}{n! k!} \left. \frac{d^k \tilde{R}_n(\phi)}{d\phi^k} \right|_{\phi(t)} \frac{\partial^n}{\partial \xi^n} \left[ \xi^k \Pi(\xi, t) \right] \quad . \quad (4.200)$$

Let's define an index  $l \equiv n + k$ , which runs from 1 to  $\infty$ . Clearly  $n = l - k$ , which for fixed  $l$  runs from 1 to  $l$ . In this way, we can reorder the terms in the sum, according to

$$\sum_{k=0}^{\infty} \sum_{n=1}^{\infty} A(k, n) = \sum_{l=1}^{\infty} \sum_{n=1}^l A(l - n, n) \quad . \quad (4.201)$$

The lowest order term on the RHS of Eqn. 4.200 is the term with  $n = 1$  and  $k = 0$ , corresponding to  $l = n = 1$  if we eliminate the  $k$  index in favor of  $l$ . It is equal to  $-\sqrt{\Omega} \tilde{R}_1(\phi(t)) \partial_{\xi} \Pi$ , hence if we demand that  $\phi(t)$  satisfy

$$\frac{d\phi}{dt} = \tilde{R}_1(\phi) \quad , \quad (4.202)$$

these terms cancel from either side of the equation. We then have

$$\frac{\partial \Pi(\xi, t)}{\partial t} = \sum_{l=2}^{\infty} \Omega^{(2-l)/2} \sum_{n=1}^l \frac{(-1)^n}{n!(l-n)!} \tilde{R}_n^{(l-n)}(\phi(t)) \frac{\partial^n}{\partial \xi^n} \left[ \xi^{l-n} \Pi(\xi, t) \right] \quad , \quad (4.203)$$

where  $\tilde{R}_n^{(k)}(\phi) = d^k \tilde{R}_n / d\phi^k$ . We are now in a position to send  $\Omega \rightarrow \infty$ , in which case only the  $l = 2$  term survives, and we are left with

$$\frac{\partial \Pi}{\partial t} = -\tilde{R}'_1(\phi(t)) \frac{\partial (\xi \Pi)}{\partial \xi} + \frac{1}{2} \tilde{R}_2(\phi(t)) \frac{\partial^2 \Pi}{\partial \xi^2} \quad , \quad (4.204)$$

which is a Fokker-Planck equation.

### Birth-death processes

Consider a birth-death process in which the states  $|n\rangle$  are labeled by nonnegative integers. Let  $\alpha_n$  denote the rate of transitions from  $|n\rangle \rightarrow |n+1\rangle$  and let  $\beta_n$  denote the rate of transitions from  $|n\rangle \rightarrow |n-1\rangle$ . The Master equation then takes the form<sup>13</sup>

$$\frac{dP_n}{dt} = \alpha_{n-1} P_{n-1} + \beta_{n+1} P_{n+1} - (\alpha_n + \beta_n) P_n \quad , \quad (4.205)$$

where we abbreviate  $P_n(t)$  for  $P(n, t | n_0, t_0)$  and suppress the initial conditions  $(n_0, t_0)$ .

Let us assume we can write  $\alpha_n = K \bar{\alpha}(n/K)$  and  $\beta_n = K \bar{\beta}(n/K)$ , where  $K \gg 1$ . Define  $x \equiv n/K$ , so the Master equation becomes

$$\begin{aligned} \frac{\partial P}{\partial t} &= K \bar{\alpha}\left(x - \frac{1}{K}\right) P\left(x - \frac{1}{K}\right) + K \bar{\beta}\left(x + \frac{1}{K}\right) P\left(x + \frac{1}{K}\right) - K (\bar{\alpha}(x) + \bar{\beta}(x)) P(x) \\ &= -\frac{\partial}{\partial x} \left[ (\bar{\alpha}(x) - \bar{\beta}(x)) P(x, t) \right] + \frac{1}{2K} \frac{\partial^2}{\partial x^2} \left[ (\bar{\alpha}(x) + \bar{\beta}(x)) P(x, t) \right] + \mathcal{O}(K^{-2}) \quad . \end{aligned} \quad (4.206)$$

If we truncate the expansion after the  $\mathcal{O}(K^{-1})$  term, we obtain

$$\frac{\partial P}{\partial t} = -\frac{\partial}{\partial x} [f(x) P(x, t)] + \frac{1}{2K} \frac{\partial^2}{\partial x^2} [g(x) P(x, t)] \quad , \quad (4.207)$$

<sup>13</sup>We further demand  $\beta_{n=0} = 0$  and  $P_{-1}(t) = 0$  at all times.

where we have defined

$$f(x) \equiv \bar{\alpha}(x) - \bar{\beta}(x) \quad , \quad g(x) \equiv \bar{\alpha}(x) + \bar{\beta}(x) \quad . \quad (4.208)$$

This FPE has an equilibrium solution

$$P_{\text{eq}}(x) = \frac{A}{g(x)} e^{-K\Phi(x)} \quad , \quad \Phi(x) = -2 \int_0^x dx' \frac{f(x')}{g(x')} \quad , \quad (4.209)$$

where the constant  $A$  is determined by normalization. If  $K$  is large, we may expand about the minimum of  $\Phi(x)$

$$\begin{aligned} \Phi(x) &= \Phi(x^*) - \frac{2f(x^*)}{g(x^*)} (x - x^*) + \frac{2f(x^*)g'(x^*) - 2g(x^*)f'(x^*)}{g^2(x^*)} (x - x^*)^2 + \dots \\ &= \Phi(x^*) - \frac{2f'(x^*)}{g(x^*)} (x - x^*)^2 + \dots \quad , \end{aligned} \quad (4.210)$$

where  $f(x^*) \equiv 0$  determines  $x^*$ . Thus, we obtain a Gaussian distribution

$$P_{\text{eq}}(x) \simeq \sqrt{\frac{K}{2\pi\sigma^2}} e^{-K(x-x^*)^2/2\sigma^2} \quad \text{with} \quad \sigma^2 = -\frac{g(x^*)}{2f'(x^*)} \quad . \quad (4.211)$$

In order that the distribution be normalizable, we must have  $f'(x^*) < 0$ .

In §4.3.6, we will see how the Fokker-Planck expansion fails to account for the large  $\mathcal{O}(K)$  fluctuations about a metastable equilibrium which lead to rare extinction events in this sort of birth-death process.

### van Kampen treatment

We now discuss the same birth-death process using van Kampen's size expansion. Assume the distribution  $P_n(t)$  has a time-dependent maximum at  $n = K\phi(t)$  and a width proportional to  $\sqrt{K}$ . We expand relative to this maximum, writing  $n \equiv K\phi(t) + \sqrt{K}\xi$  and we define  $P_n(t) \equiv \Pi(\xi, t)$ . We now rewrite the Master equation in eqn. 4.205 in terms of  $\Pi(\xi, t)$ . Since  $n$  is an independent variable, we set

$$dn = K\dot{\phi} dt + \sqrt{K} d\xi \quad \Rightarrow \quad d\xi|_n = -\sqrt{K} \dot{\phi} dt \quad . \quad (4.212)$$

Therefore

$$\frac{dP_n}{dt} = -\sqrt{K} \dot{\phi} \frac{\partial \Pi}{\partial \xi} + \frac{\partial \Pi}{\partial t} \quad . \quad (4.213)$$

We now write

$$\begin{aligned} \alpha_{n-1} P_{n-1} &= K \bar{\alpha}(\phi + K^{-1/2}\xi - K^{-1}) \Pi(\xi - K^{-1/2}) \\ \beta_{n+1} P_{n+1} &= K \bar{\beta}(\phi + K^{-1/2}\xi + K^{-1}) \Pi(\xi + K^{-1/2}) \\ (\alpha_n + \beta_n) P_n &= K \bar{\alpha}(\phi + K^{-1/2}\xi) \Pi(\xi) + K \bar{\beta}(\phi + K^{-1/2}\xi) \Pi(\xi) \quad , \end{aligned} \quad (4.214)$$

and therefore Eqn. 4.205 becomes

$$-\sqrt{K} \frac{\partial \Pi}{\partial \xi} \dot{\phi} + \frac{\partial \Pi}{\partial t} = \sqrt{K} (\bar{\beta} - \bar{\alpha}) \frac{\partial \Pi}{\partial \xi} + (\bar{\beta}' - \bar{\alpha}') \xi \frac{\partial \Pi}{\partial \xi} + (\bar{\beta}' - \bar{\alpha}') \Pi + \frac{1}{2} (\bar{\alpha} + \bar{\beta}) \frac{\partial^2 \Pi}{\partial \xi^2} + \mathcal{O}(K^{-1/2}) \quad , \quad (4.215)$$

where  $\bar{\alpha} = \bar{\alpha}(\phi)$  and  $\bar{\beta} = \bar{\beta}(\phi)$ . Equating terms of order  $\sqrt{K}$  yields the equation

$$\dot{\phi} = f(\phi) \equiv \bar{\alpha}(\phi) - \bar{\beta}(\phi) \quad , \quad (4.216)$$

which is a first order ODE for the quantity  $\phi(t)$ . Equating terms of order  $K^0$  yields the Fokker-Planck equation,

$$\frac{\partial \Pi}{\partial t} = -f'(\phi(t)) \frac{\partial}{\partial \xi} (\xi \Pi) + \frac{1}{2} g(\phi(t)) \frac{\partial^2 \Pi}{\partial \xi^2} \quad , \quad (4.217)$$

where  $g(\phi) \equiv \bar{\alpha}(\phi) + \bar{\beta}(\phi)$ . If in the limit  $t \rightarrow \infty$ , eqn. 4.216 evolves to a stable fixed point  $\phi^*$ , then the stationary solution of the Fokker-Planck eqn. 4.217,  $\Pi_{\text{eq}}(\xi) = \Pi(\xi, t = \infty)$  must satisfy

$$-f'(\phi^*) \frac{\partial}{\partial \xi} (\xi \Pi_{\text{eq}}) + \frac{1}{2} g(\phi^*) \frac{\partial^2 \Pi_{\text{eq}}}{\partial \xi^2} = 0 \quad \Rightarrow \quad \Pi_{\text{eq}}(\xi) = \frac{1}{\sqrt{2\pi\sigma^2}} e^{-\xi^2/2\sigma^2} \quad , \quad (4.218)$$

where

$$\sigma^2 = -\frac{g(\phi^*)}{2f'(\phi^*)} \quad . \quad (4.219)$$

Now both  $\alpha$  and  $\beta$  are rates, hence both are positive and thus  $g(\phi) > 0$ . We see that the condition  $\sigma^2 > 0$ , which is necessary for a normalizable equilibrium distribution, requires  $f'(\phi^*) < 0$ , which is saying that the fixed point in Eqn. 4.216 is stable.

We thus arrive at the same distribution as in Eqn. 4.211. The virtue of this latter approach is that we have a better picture of how the distribution evolves toward its equilibrium value. The condition of normalizability  $f'(x^*) < 0$  is now seen to be connected with the dynamics of location of the instantaneous maximum of  $P(x, t)$ , namely  $x = \phi(t)$ . If the dynamics of the FPE in Eqn. 4.217 are fast compared with those of the simple dynamical system in Eqn. 4.216, we may regard the evolution of  $\phi(t)$  as adiabatic so far as  $\Pi(\xi, t)$  is concerned.

### 4.3.6 Extinction times in birth-death processes

In §4.3.1 we discussed the Master equation for birth-death processes,

$$\frac{dP_n}{dt} = t^+(n-1)P_{n-1} + t^-(n+1)P_{n+1} - [t^+(n) + t^-(n)]P_n \quad . \quad (4.220)$$

At the mean field level, we have for the average population  $\bar{n} = \sum_n n P_n$ ,

$$\frac{d\bar{n}}{dt} = t^+(\bar{n}) - t^-(\bar{n}) \quad . \quad (4.221)$$

Two models from population biology that merit our attention here:

- **Susceptible-infected-susceptible (SIS) model** : Consider a population of fixed total size  $N$ , among which  $n$  individuals are infected and the remaining  $N - n$  are susceptible. The number of possible contacts between infected and susceptible individuals is then  $n(N - n)$ , and if the infection rate per contact is  $\Lambda/N$  and the recovery rate of infected individuals is set to unity<sup>14</sup>, then we have

$$t^+(n) = \Lambda n \left(1 - \frac{n}{N}\right) \quad , \quad t^-(n) = n \quad . \quad (4.222)$$

- **Verhulst model** : Here the birth rate is  $B$  and the death rate is unity plus a stabilizing term  $(B/N)n$  which increases linearly with population size. Thus,

$$t^+(n) = Bn \quad , \quad t^-(n) = n + \frac{Bn^2}{N} \quad . \quad (4.223)$$

The mean field dynamics of both models is the same, with

$$\frac{d\bar{n}}{dt} = (\Lambda - 1)\bar{n} - \frac{\Lambda\bar{n}^2}{N} \quad (4.224)$$

for the SIS model; take  $\Lambda \rightarrow B$  for the Verhulst model. This is known as the *logistic equation*:  $\dot{\bar{n}} = r\bar{n}(K - \bar{n})$ , with  $r = \Lambda/N$  the growth rate and  $K = (\Lambda - 1)/\Lambda$  the equilibrium population. If  $\Lambda > 1$  then  $K > 0$ , in which case the fixed point at  $\bar{n} = 0$  is unstable and the fixed point at  $\bar{n} = K$  is stable. The asymptotic state is one of an equilibrium number  $K$  of infected individuals. At  $\Lambda = 1$  there is a transcritical bifurcation, and for  $0 < \Lambda < 1$  we have  $K < 0$ , and the unphysical fixed point at  $\bar{n} = K$  is unstable, while the fixed point at  $\bar{n} = 0$  is stable. The infection inexorably dies out. So the mean field dynamics for  $\Lambda > 1$  are a simple flow to the stable fixed point (SFP) at  $\bar{n} = K$ , and those for  $\Lambda < 1$  are a flow to the SFP at  $\bar{n} = 0$ . In both cases, the approach to the SFP takes a logarithmically infinite amount of time.

Although the mean field solution for  $\Lambda > 1$  asymptotically approaches an equilibrium number of infected individuals  $K$ , the stochasticity in this problem means that *there is a finite extinction time for the infection*. The extinction time is the first passage time to the state  $n = 0$ . Once the population of infected individuals goes to zero, there is no way for new infections to spontaneously develop. The mean first passage time was studied in §4.3.4. We have an absorbing boundary at  $n = 1$ , since  $t^+(0) = 0$ , and a reflecting boundary at  $n = N$ , since  $t^+(N) = 0$ , and Eqn. 4.182 gives the mean first passage time for absorption as

$$T(n) = \sum_{k=1}^n \phi(k) \sum_{j=k}^N \frac{1}{t^+(j) \phi(j)} \quad , \quad (4.225)$$

where<sup>15</sup>

$$\phi(k) = \prod_{l=1}^k \frac{t^-(l)}{t^+(l)} \quad . \quad (4.226)$$

<sup>14</sup>That is, we measure time in units of the recovery time.

<sup>15</sup>In §4.3.4, we defined  $\phi(a) = 1$  where  $a = 1$  is the absorbing boundary here, whereas in Eqn. 4.226 we have  $\phi(1) = t^+(1)/t^-(1)$ . Since the mean first passage time  $T(n)$  does not change when all  $\phi(n)$  are multiplied by the same constant, we are free to define  $\phi(a)$  any way we please. In this chapter it pleases me to define it as described.

The detailed analysis of  $T(n)$  is rather tedious, and is described in the appendices to C. Doering *et al.*, *Multiscale Model Simul.* **3**, 283 (2005). For our purposes, it suffices to consider the behavior of the function  $\phi(n)$ . Let  $x \equiv n/N \in [0, 1]$ . Then with  $y \equiv j/N$  define

$$\rho(y) \equiv \frac{t^+(j)}{t^-(j)} = \Lambda(1 - y) \quad , \quad (4.227)$$

in which case, using the trapezoidal rule, and setting  $x \equiv n/N$ ,

$$\begin{aligned} -\ln \phi(n) &= \sum_{l=1}^n \ln \rho(l/N) \\ &\approx -\frac{1}{2} \ln \rho(0) - \frac{1}{2} \ln \rho(x) + N \int_0^x du \ln \rho(u) \\ &= N \left\{ \ln \Lambda - (1-x) \ln \Lambda - (1-x) \ln(1-x) - x \right\} - \ln \Lambda - \frac{1}{2} \ln(1-x) \quad . \end{aligned} \quad (4.228)$$

In the  $N \rightarrow \infty$  limit, the maximum occurs at  $x^* = (\Lambda - 1)/\Lambda$ , which for  $\Lambda > 1$  is the scaled mean field equilibrium population of infected individuals. For  $x \approx x^*$ , the mean extinction time for the infection is therefore

$$T(x^*) \sim e^{N\Phi(\Lambda)} \quad , \quad \Phi(\Lambda) = \ln \Lambda - 1 + \Lambda^{-1} \quad . \quad (4.229)$$

The full result, from Doering *et al.*, is

$$T(x^*) = \frac{\Lambda}{(\Lambda - 1)^2} \sqrt{\frac{2\pi}{N}} e^{N(\ln \Lambda - 1 + \Lambda^{-1})} \times \left( 1 + \mathcal{O}(N^{-1}) \right) \quad (4.230)$$

The extinction time is exponentially large in the population size.

Below threshold, when  $\Lambda < 1$ , Doering *et al.* find

$$T(x) = \frac{\ln(Nx)}{1 - \Lambda} + \mathcal{O}(1) \quad , \quad (4.231)$$

which is logarithmic in  $N$ . From the mean field dynamics  $\dot{\bar{n}} = (\Lambda - 1)\bar{n} - \Lambda\bar{n}^2$ , if we are sufficiently close to the SFP at  $\bar{n} = 0$ , we can neglect the nonlinear term, in which case the solution becomes  $\bar{n}(t) = \bar{n}(0) e^{(\Lambda-1)t}$ . If we set  $\bar{n}(T) \equiv 1$  and  $\bar{n}(0) = Nx$ , we obtain  $T(x) = \ln(Nx)/(1 - \Lambda)$ , in agreement with the above expression.

### Fokker-Planck solution

Another approach to this problem is to map the Master equation onto a Fokker-Planck equation, as we did in §4.3.5. The corresponding FPE is

$$\frac{\partial P}{\partial t} = -\frac{\partial}{\partial x}(fP) + \frac{1}{2N} \frac{\partial^2}{\partial x^2}(gP) \quad , \quad (4.232)$$

where

$$\begin{aligned} f(x) &= (\Lambda - 1)x - \Lambda x^2 = \Lambda x(x^* - x) \\ g(x) &= (\Lambda + 1)x - \Lambda x^2 = \Lambda x(x^* + 2\Lambda^{-1} - x) \end{aligned} \quad (4.233)$$

The mean extinction time, from Eqn. 4.63, is

$$T(x) = 2N \int_0^x \frac{dy}{\psi(y)} \int_y^1 dz \frac{\psi(z)}{g(z)} \quad , \quad (4.234)$$

where

$$\psi(x) = \exp \left\{ 2N \int_0^x dy \frac{f(y)}{g(y)} \right\} \equiv e^{2N\sigma(x)} \quad (4.235)$$

and

$$\sigma(x) = x + 2\Lambda^{-1} \ln \left( \frac{x^* + 2\Lambda^{-1} - x}{x^* + 2\Lambda^{-1}} \right) \quad . \quad (4.236)$$

Thus,

$$T(x) = \frac{2N}{\Lambda} \int_0^x dy \int_y^1 dz \frac{e^{2N\sigma(z)} e^{-2N\sigma(y)}}{z(x^* + 2\Lambda^{-1} - z)} \quad . \quad (4.237)$$

The  $z$  integral is dominated by  $z \approx x^*$ , and the  $y$  integral by  $y \approx 0$ . Computing the derivatives for the Taylor series,

$$\sigma(x^*) = \frac{\Lambda - 1}{\Lambda} - \frac{2}{\Lambda} \ln \left( \frac{\Lambda + 1}{2} \right) \quad , \quad \sigma'(x^*) = 0 \quad , \quad \sigma''(x^*) = -\frac{1}{2}\Lambda \quad (4.238)$$

and also  $\sigma(0) = 0$  and  $\sigma'(0) = (\Lambda - 1)/(\Lambda + 1)$ . One then finds

$$T(x^*) \approx \frac{\Lambda}{(\Lambda - 1)^2} \sqrt{\frac{2\pi}{N\Lambda}} e^{2N\sigma(x^*)} \quad . \quad (4.239)$$

### Comparison of Master and Fokker-Planck equation predictions for extinction times

How does the FPE result compare with the earlier analysis of the extinction time from the Master equation? If we expand about the threshold value  $\Lambda = 1$ , writing  $\Lambda = 1 + \varepsilon$ , we find

$$\begin{aligned} \Phi(\Lambda) &= \ln \Lambda - 1 + \Lambda^{-1} = \frac{1}{2}\varepsilon^2 - \frac{2}{3}\varepsilon^3 + \frac{3}{4}\varepsilon^4 - \frac{4}{5}\varepsilon^5 + \dots \\ 2\sigma(x^*) &= \frac{2(\Lambda - 1)}{\Lambda} - \frac{4}{\Lambda} \ln \left( \frac{\Lambda + 1}{2} \right) = \frac{1}{2}\varepsilon^2 - \frac{2}{3}\varepsilon^3 + \frac{35}{48}\varepsilon^4 - \frac{181}{240}\varepsilon^5 + \dots \end{aligned} \quad (4.240)$$

The difference only begins at fourth order in  $\varepsilon$  *viz.*

$$\ln T^{\text{ME}}(x^*) - \ln T^{\text{FPE}}(x^*) = N \left( \frac{\varepsilon^4}{48} - \frac{11\varepsilon^5}{240} + \frac{11\varepsilon^6}{160} + \dots \right) + \mathcal{O}(1) \quad , \quad (4.241)$$

where the superscripts indicate Master equation (ME) and Fokker-Planck equation (FPE), respectively. While the term inside the parentheses impressively small when  $\varepsilon \ll 1$ , it is nevertheless finite, and, critically, *it is multiplied by  $N$* . Thus, the actual mean extinction time, as computed from the original Master equation, is exponentially larger than the Fokker-Planck result.

What are we to learn from this? The origin of the difference lies in the truncations we had to do in order to derive the Fokker-Planck equation itself. The FPE fails to accurately capture the statistics of large deviations from the metastable state. D. Kessler and N. Shnerb, in *J. Stat. Phys.* **127**, 861 (2007), show that the FPE is only valid for fluctuations about the metastable state whose size is  $\mathcal{O}(N^{2/3})$ , whereas to reach the absorbing state requires a fluctuation of  $\mathcal{O}(N)$ . As these authors put it, "*In order to get the correct statistics for rare and extreme events one should base the estimate on the exact Master equation that describes the stochastic process...*". They also derive a real space WKB method to extract the correct statistics from the Master equation. Another WKB-like treatment, and one which utilizes the powerful Doi-Peliti field theory formalism, is found in the paper by V. Elgart and A. Kamenev, *Phys. Rev. E* **70**, 041106 (2004).