

Problem #1

A small car with mass 0.800 kg travels at constant speed on the inside of a track that is a vertical circle with radius 5.00 m . If the normal force exerted by the track on the car when it is at the top of the track (point B) is 6.00 N , what is the normal force on the car when it is at the bottom of the track (point A)?

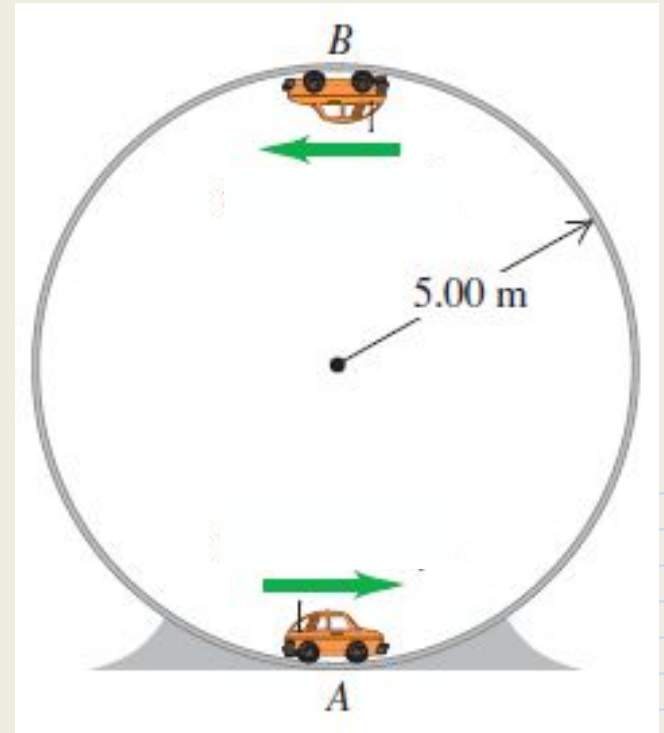

Problem #2

In the figure below, block B has mass 5.00 kg and block A has mass 8.00 kg. There is no friction between block A and the tabletop, but the coefficient of static friction between block B and block A is 0.75. What is the largest mass that block C can have such that blocks A and B still slide together when the system is released from rest?

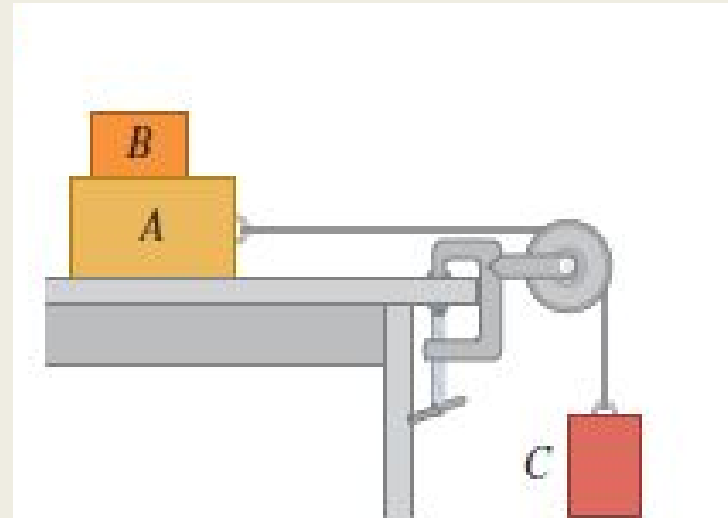

Problem #3

Two blocks with masses 4.00 kg and 8.00 kg are connected by a string and slid down a ramp, as shown. The coefficient of kinetic friction between the 4.00 kg block and the ramp is 0.25 and between the 8.00 kg block and the ramp is 0.35. (a) What is the acceleration of each block? (b) What is the tension in the string?

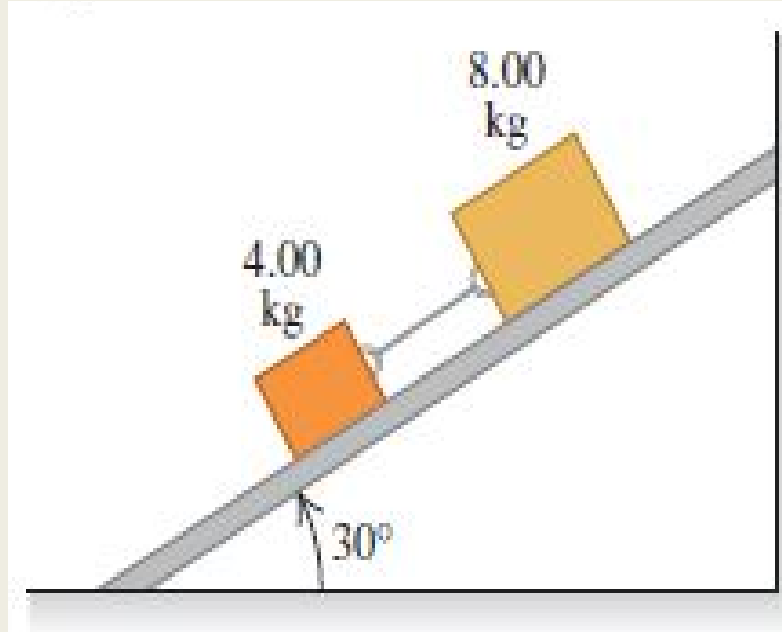

Problem #4

The “Giant Swing” at a county fair consists of a vertical rotating central shaft connected to a seat by two cables (as shown in the figure). The seat swings in a horizontal circle at a rate of 32.0 rev/min. If the seat weighs 255 N and an 825-N person is sitting in it, find the tension in each cable.

