

## Chapter 4

# Linear Oscillations

Harmonic motion is ubiquitous in Physics. The reason is that any potential energy function, when expanded in a Taylor series in the vicinity of a local minimum, is a harmonic function:

$$U(\vec{q}) = U(\vec{q}^*) + \sum_{j=1}^N \overbrace{\left. \frac{\partial U}{\partial q_j} \right|_{\vec{q}=\vec{q}^*}}^{\nabla U(\vec{q}^*)=0} (q_j - q_j^*) + \frac{1}{2} \sum_{j,k=1}^N \left. \frac{\partial^2 U}{\partial q_j \partial q_k} \right|_{\vec{q}=\vec{q}^*} (q_j - q_j^*) (q_k - q_k^*) + \dots, \quad (4.1)$$

where the  $\{q_j\}$  are *generalized coordinates* – more on this when we discuss Lagrangians. In one dimension, we have simply

$$U(x) = U(x^*) + \frac{1}{2} U''(x^*) (x - x^*)^2 + \dots. \quad (4.2)$$

Provided the deviation  $\eta = x - x^*$  is small enough in magnitude, the remaining terms in the Taylor expansion may be ignored. Newton's Second Law then gives

$$m \ddot{\eta} = -U''(x^*) \eta + \mathcal{O}(\eta^2). \quad (4.3)$$

This, to lowest order, is the equation of motion for a harmonic oscillator. If  $U''(x^*) > 0$ , the equilibrium point  $x = x^*$  is *stable*, since for small deviations from equilibrium the restoring force pushes the system back toward the equilibrium point. When  $U''(x^*) < 0$ , the equilibrium is *unstable*, and the forces push one further away from equilibrium.

### 4.1 Damped Harmonic Oscillator

In the real world, there are frictional forces, which we here will approximate by  $F = -\gamma v$ . We begin with the homogeneous equation for a damped harmonic oscillator,

$$\frac{d^2x}{dt^2} + 2\beta \frac{dx}{dt} + \omega_0^2 x = 0, \quad (4.4)$$

where  $\gamma = 2\beta m$ . To solve, write  $x(t) = \sum_i C_i e^{-i\omega_i t}$ . This renders the differential equation 4.4 an *algebraic* equation for the two eigenfrequencies  $\omega_i$ , each of which must satisfy

$$\omega^2 + 2i\beta\omega - \omega_0^2 = 0, \quad (4.5)$$

hence

$$\omega_{\pm} = -i\beta \pm (\omega_0^2 - \beta^2)^{1/2}. \quad (4.6)$$

The most general solution to eqn. 4.4 is then

$$x(t) = C_+ e^{-i\omega_+ t} + C_- e^{-i\omega_- t} \quad (4.7)$$

where  $C_{\pm}$  are arbitrary constants. Notice that the eigenfrequencies are in general complex, with a negative imaginary part (so long as the damping coefficient  $\beta$  is positive). Thus  $e^{-i\omega_{\pm} t}$  decays to zero as  $t \rightarrow \infty$ .

#### 4.1.1 Classification of damped harmonic motion

We identify three classes of motion:

- (i) Underdamped ( $\omega_0^2 > \beta^2$ ) :  $x(t) = C e^{-\beta t} \cos(\nu t) + D e^{-\beta t} \sin(\nu t)$
- (ii) Overdamped ( $\omega_0^2 < \beta^2$ ) :  $x(t) = C e^{-\beta t} \cosh(\tilde{\nu} t) + D e^{-\beta t} \sinh(\tilde{\nu} t)$
- (iii) Critically Damped ( $\omega_0^2 = \beta^2$ ) :  $x(t) = C e^{-\beta t} + D t e^{-\beta t}$

where  $\nu \equiv (\omega_0^2 - \beta^2)^{1/2}$  and  $\tilde{\nu} \equiv i\nu = (\beta^2 - \omega_0^2)^{1/2}$ . Note that for case (i)  $\nu$  is real and  $\tilde{\nu}$  is imaginary, while for case (ii)  $\tilde{\nu}$  is real and  $\nu$  is imaginary. Note also that the form for  $x(t)$  in case (i) can be applied to case (ii), and *vice versa*, since

$$\begin{aligned} \cos(\nu t) &= \cos(-i\tilde{\nu} t) = \cosh(\tilde{\nu} t) \\ \sin(\nu t) &= \sin(-i\tilde{\nu} t) = \sinh(\tilde{\nu} t). \end{aligned}$$

The three types of behavior are depicted in fig. 4.1. To concretize these cases in one's mind, it is helpful to think of the case of a screen door or a shock absorber. If the hinges on the door are underdamped, the door will swing back and forth (assuming it doesn't have a rim which smacks into the door frame) several times before coming to a stop. If the hinges are overdamped, the door may take a very long time to close. To see this, note that the overdamped solution can also be written as

$$x(t) = A e^{-(\beta - \sqrt{\beta^2 - \omega_0^2})t} + B e^{-(\beta + \sqrt{\beta^2 - \omega_0^2})t}, \quad (4.8)$$

with  $A = \frac{1}{2}(C + D)$  and  $B = \frac{1}{2}(C - D)$ . We now expand the expression  $\sqrt{\beta^2 - \omega_0^2}$  in powers of  $\omega_0^2/\beta^2$ :

$$\begin{aligned} \sqrt{\beta^2 - \omega_0^2} &= \beta \left(1 - \frac{\omega_0^2}{\beta^2}\right)^{-1/2} \\ &= \beta \left(1 - \frac{\omega_0^2}{2\beta^2} - \frac{\omega_0^4}{8\beta^4} + \dots\right), \end{aligned} \quad (4.9)$$

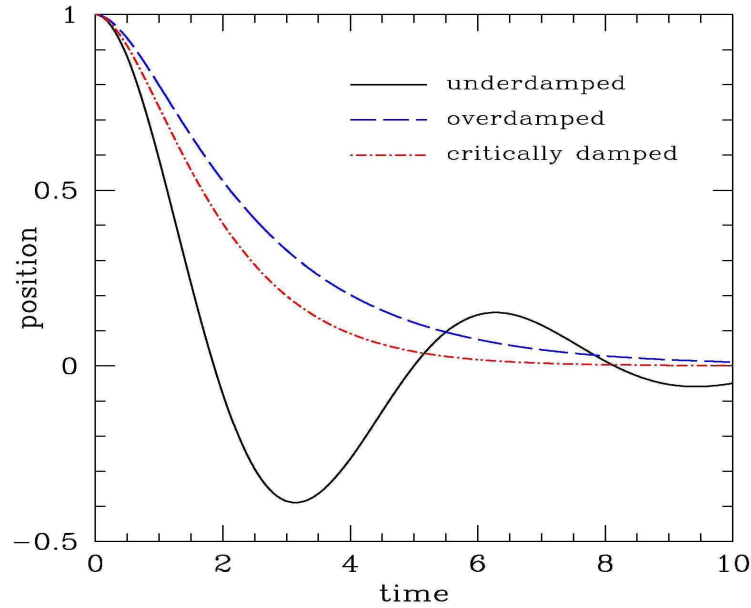

Figure 4.1: Three classifications of damped harmonic motion. The initial conditions are  $x(0) = 1$ ,  $\dot{x}(0) = 0$ .

which leads to

$$\begin{aligned}\beta - \sqrt{\beta^2 - \omega_0^2} &= \frac{\omega_0^2}{2\beta} + \frac{\omega_0^4}{8\beta^3} + \dots \\ \beta + \sqrt{\beta^2 - \omega_0^2} &= 2\beta - \frac{\omega_0^2}{2\beta} - \dots\end{aligned}\quad (4.10)$$

Thus, we can write

$$x(t) = A e^{-t/\tau_1} + B e^{-t/\tau_2}, \quad (4.11)$$

with

$$\tau_1 = \frac{1}{\beta - \sqrt{\beta^2 - \omega_0^2}} \approx \frac{2\beta}{\omega_0^2} \quad (4.12)$$

$$\tau_2 = \frac{1}{\beta + \sqrt{\beta^2 - \omega_0^2}} \approx \frac{1}{2\beta}. \quad (4.13)$$

Thus  $x(t)$  is a sum of exponentials, with decay times  $\tau_{1,2}$ . For  $\beta \gg \omega_0$ , we have that  $\tau_1$  is much larger than  $\tau_2$  – the ratio is  $\tau_1/\tau_2 \approx 4\beta^2/\omega_0^2 \gg 1$ . Thus, on time scales on the order of  $\tau_1$ , the second term has completely damped away. The decay time  $\tau_1$ , though, is very long, since  $\beta$  is so large. So a highly overdamped oscillator will take a very long time to come to equilibrium.

### 4.1.2 Remarks on the case of critical damping

Define the first order differential operator

$$\mathcal{D}_t = \frac{d}{dt} + \beta . \quad (4.14)$$

The solution to  $\mathcal{D}_t x(t) = 0$  is  $\tilde{x}(t) = A e^{-\beta t}$ , where  $A$  is a constant. Note that the *commutator* of  $\mathcal{D}_t$  and  $t$  is unity:

$$[\mathcal{D}_t, t] = 1 , \quad (4.15)$$

where  $[A, B] \equiv AB - BA$ . The simplest way to verify eqn. 4.15 is to compute its action upon an arbitrary function  $f(t)$ :

$$\begin{aligned} [\mathcal{D}_t, t] f(t) &= \left( \frac{d}{dt} + \beta \right) t f(t) - t \left( \frac{d}{dt} + \beta \right) f(t) \\ &= \frac{d}{dt} (t f(t)) - t \frac{d}{dt} f(t) = f(t) . \end{aligned} \quad (4.16)$$

We know that  $x(t) = \tilde{x}(t) = A e^{-\beta t}$  satisfies  $\mathcal{D}_t x(t) = 0$ . Therefore

$$\begin{aligned} 0 &= \mathcal{D}_t [\mathcal{D}_t, t] \tilde{x}(t) \\ &= \mathcal{D}_t^2 (t \tilde{x}(t)) - \mathcal{D}_t t \overbrace{\mathcal{D}_t \tilde{x}(t)}^0 \\ &= \mathcal{D}_t^2 (t \tilde{x}(t)) . \end{aligned} \quad (4.17)$$

We already know that  $\mathcal{D}_t^2 \tilde{x}(t) = \mathcal{D}_t \mathcal{D}_t \tilde{x}(t) = 0$ . The above equation establishes that the second independent solution to the second order ODE  $\mathcal{D}_t^2 x(t) = 0$  is  $x(t) = t \tilde{x}(t)$ . Indeed, we can keep going, and show that

$$\mathcal{D}_t^n (t^{n-1} \tilde{x}(t)) = 0 . \quad (4.18)$$

Thus, the  $n$  independent solutions to the  $n^{\text{th}}$  order ODE

$$\left( \frac{d}{dt} + \beta \right)^n x(t) = 0 \quad (4.19)$$

are

$$x_k(t) = A t^k e^{-\beta t} , \quad k = 0, 1, \dots, n-1 . \quad (4.20)$$

## 4.2 Damped Harmonic Oscillator with Forcing

When forced, the equation for the damped oscillator becomes

$$\frac{d^2 x}{dt^2} + 2\beta \frac{dx}{dt} + \omega_0^2 x = f(t) , \quad (4.21)$$

where  $f(t) = F(t)/m$ . Since this equation is linear in  $x(t)$ , we can, without loss of generality, restrict our attention to harmonic forcing terms of the form

$$f(t) = f_0 \cos(\Omega t + \varphi_0) = \operatorname{Re} \left[ f_0 e^{-i\varphi_0} e^{-i\Omega t} \right] \quad (4.22)$$

where  $\operatorname{Re}$  stands for “real part”. Here,  $\Omega$  is the forcing frequency.

Consider first the complex equation

$$\frac{d^2 z}{dt^2} + 2\beta \frac{dz}{dt} + \omega_0^2 z = f_0 e^{-i\varphi_0} e^{-i\Omega t} . \quad (4.23)$$

We try a solution  $z(t) = z_0 e^{-i\Omega t}$ . Plugging in, we obtain the algebraic equation

$$z_0 = \frac{f_0 e^{-i\varphi_0}}{\omega_0^2 - 2i\beta\Omega - \Omega^2} \equiv A(\Omega) e^{i\delta(\Omega)} f_0 e^{-i\varphi_0} . \quad (4.24)$$

The amplitude  $A(\Omega)$  and phase shift  $\delta(\Omega)$  are given by the equation

$$A(\Omega) e^{i\delta(\Omega)} = \frac{1}{\omega_0^2 - 2i\beta\Omega - \Omega^2} . \quad (4.25)$$

A basic fact of complex numbers:

$$\frac{1}{a - ib} = \frac{a + ib}{a^2 + b^2} = \frac{e^{i \tan^{-1}(b/a)}}{\sqrt{a^2 + b^2}} . \quad (4.26)$$

Thus,

$$A(\Omega) = \left( (\omega_0^2 - \Omega^2)^2 + 4\beta^2 \Omega^2 \right)^{-1/2} \quad (4.27)$$

$$\delta(\Omega) = \tan^{-1} \left( \frac{2\beta\Omega}{\omega_0^2 - \Omega^2} \right) . \quad (4.28)$$

Now since the coefficients  $\beta$  and  $\omega_0^2$  are real, we can take the complex conjugate of eqn. 4.23, and write

$$\ddot{\bar{z}} + 2\beta \dot{\bar{z}} + \omega_0^2 \bar{z} = f_0 e^{-i\varphi_0} e^{-i\Omega t} \quad (4.29)$$

$$\ddot{\bar{z}} + 2\beta \dot{\bar{z}} + \omega_0^2 \bar{z} = f_0 e^{+i\varphi_0} e^{+i\Omega t} , \quad (4.30)$$

where  $\bar{z}$  is the complex conjugate of  $z$ . We now add these two equations and divide by two to arrive at

$$\ddot{x} + 2\beta \dot{x} + \omega_0^2 x = f_0 \cos(\Omega t + \varphi_0) . \quad (4.31)$$

Therefore, the real, physical solution we seek is

$$\begin{aligned} x_{\text{inh}}(t) &= \operatorname{Re} \left[ A(\Omega) e^{i\delta(\Omega)} \cdot f_0 e^{-i\varphi_0} e^{-i\Omega t} \right] \\ &= A(\Omega) f_0 \cos(\Omega t + \varphi_0 - \delta(\Omega)) . \end{aligned} \quad (4.32)$$

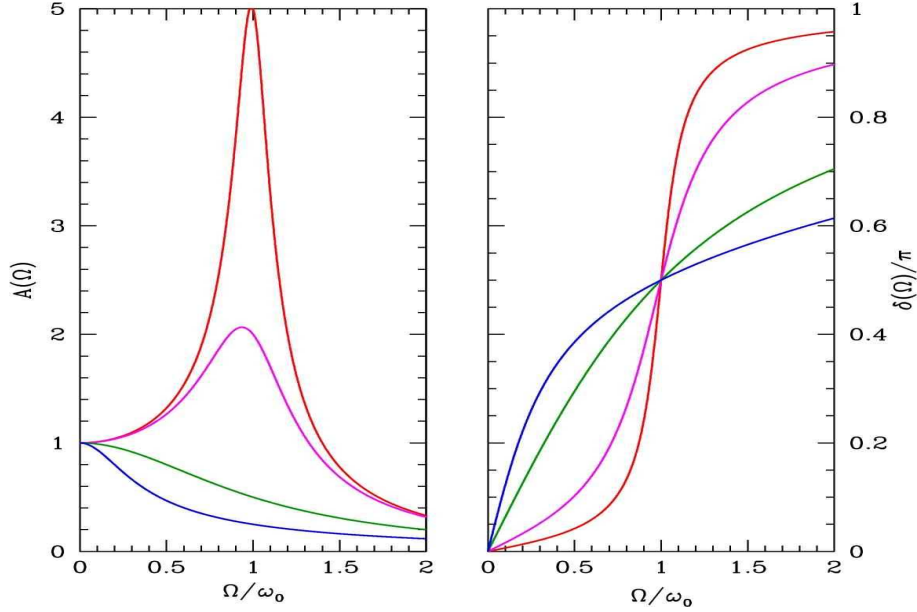

Figure 4.2: Amplitude and phase shift *versus* oscillator frequency (units of  $\omega_0$ ) for  $\beta/\omega_0$  values of 0.1 (red), 0.25 (magenta), 1.0 (green), and 2.0 (blue).

The quantity  $A(\Omega)$  is the *amplitude* of the response (in units of  $f_0$ ), while  $\delta(\Omega)$  is the (dimensionless) *phase lag*.

The maximum of the amplitude  $A(\Omega)$  occurs when  $A'(\Omega) = 0$ . From

$$\frac{dA}{d\Omega} = -\frac{2\Omega}{[A(\Omega)]^3} (\Omega^2 - \omega_0^2 + 2\beta^2), \quad (4.33)$$

we conclude that  $A'(\Omega) = 0$  for  $\Omega = 0$  and for  $\Omega = \Omega_R$ , where

$$\Omega_R = \sqrt{\omega_0^2 - 2\beta^2}. \quad (4.34)$$

The solution at  $\Omega = \Omega_R$  pertains only if  $\omega_0^2 > 2\beta^2$ , of course, in which case  $\Omega = 0$  is a local minimum and  $\Omega = \Omega_R$  a local maximum. If  $\omega_0^2 < 2\beta^2$  there is only a local maximum, at  $\Omega = 0$ . See Fig. 4.2.

Since equation 4.21 is linear, we can add a solution to the homogeneous equation to  $x_{\text{inh}}(t)$  and we will still have a solution. Thus, the most general solution to eqn. 4.21 is

$$\begin{aligned} x(t) &= x_{\text{inh}}(t) + x_{\text{hom}}(t) \\ &= \text{Re} \left[ A(\Omega) e^{i\delta(\Omega)} \cdot f_0 e^{-i\varphi_0} e^{-i\Omega t} \right] + C_+ e^{-i\omega_+ t} + C_- e^{-i\omega_- t} \\ &= \underbrace{A(\Omega) f_0 \cos(\Omega t + \varphi_0 - \delta(\Omega))}_{x_{\text{inh}}(t)} + \underbrace{C e^{-\beta t} \cos(\nu t) + D e^{-\beta t} \sin(\nu t)}_{x_{\text{hom}}(t)}. \end{aligned} \quad (4.35)$$

The last two terms in eqn. 4.35 are the solution to the homogeneous equation, *i.e.* with  $f(t) = 0$ . They are necessary to include because they carry with them the two constants of integration which always arise in the solution of a second order ODE. That is,  $C$  and  $D$  are adjusted so as to satisfy  $x(0) = x_0$  and  $\dot{x}_0 = v_0$ . However, due to their  $e^{-\beta t}$  prefactor, these terms decay to zero once  $t$  reaches a relatively low multiple of  $\beta^{-1}$ . They are called *transients*, and may be set to zero if we are only interested in the long time behavior of the system. This means, incidentally, that the initial conditions are effectively forgotten over a time scale on the order of  $\beta^{-1}$ .

For  $\Omega_{\text{R}} > 0$ , one defines the *quality factor*,  $Q$ , of the oscillator by  $Q = \Omega_{\text{R}}/2\beta$ .  $Q$  is a rough measure of how many periods the unforced oscillator executes before its initial amplitude is damped down to a small value. For a forced oscillator driven near resonance, and for weak damping,  $Q$  is also related to the ratio of average energy in the oscillator to the energy lost per cycle by the external source. To see this, let us compute the energy lost per cycle,

$$\begin{aligned} \Delta E &= m \int_0^{2\pi/\Omega} dt \dot{x} f(t) \\ &= -m \int_0^{2\pi/\Omega} dt \Omega A f_0^2 \sin(\Omega t + \varphi_0 - \delta) \cos(\Omega t + \varphi_0) \\ &= \pi A f_0^2 m \sin \delta \\ &= 2\pi\beta m \Omega A^2(\Omega) f_0^2, \end{aligned} \tag{4.36}$$

since  $\sin \delta(\Omega) = 2\beta\Omega A(\Omega)$ . The oscillator energy, averaged over the cycle, is

$$\begin{aligned} \langle E \rangle &= \frac{\Omega}{2\pi} \int_0^{2\pi/\Omega} dt \frac{1}{2} m (\dot{x}^2 + \omega_0^2 x^2) \\ &= \frac{1}{4} m (\Omega^2 + \omega_0^2) A^2(\Omega) f_0^2. \end{aligned} \tag{4.37}$$

Thus, we have

$$\frac{2\pi\langle E \rangle}{\Delta E} = \frac{\Omega^2 + \omega_0^2}{4\beta\Omega}. \tag{4.38}$$

Thus, for  $\Omega \approx \Omega_{\text{R}}$  and  $\beta^2 \ll \omega_0^2$ , we have

$$Q \approx \frac{2\pi\langle E \rangle}{\Delta E} \approx \frac{\omega_0}{2\beta}. \tag{4.39}$$

### 4.2.1 Resonant forcing

When the damping  $\beta$  vanishes, the response diverges at resonance. The solution to the resonantly forced oscillator

$$\ddot{x} + \omega_0^2 x = f_0 \cos(\omega_0 t + \varphi_0) \tag{4.40}$$

is given by

$$x(t) = \frac{f_0}{2\omega_0} t \sin(\omega_0 t + \varphi_0) + \overbrace{A \cos(\omega_0 t) + B \sin(\omega_0 t)}^{x_{\text{hom}}(t)} . \quad (4.41)$$

The amplitude of this solution grows linearly due to the energy pumped into the oscillator by the resonant external forcing. In the real world, nonlinearities can mitigate this unphysical, unbounded response.

### 4.2.2 $R$ - $L$ - $C$ circuits

Consider the  $R$ - $L$ - $C$  circuit of Fig. 4.3. When the switch is to the left, the capacitor is charged, eventually to a steady state value  $Q = CV$ . At  $t = 0$  the switch is thrown to the right, completing the  $R$ - $L$ - $C$  circuit. Recall that the sum of the voltage drops across the three elements must be zero:

$$L \frac{dI}{dt} + IR + \frac{Q}{C} = 0 . \quad (4.42)$$

We also have  $\dot{Q} = I$ , hence

$$\frac{d^2Q}{dt^2} + \frac{R}{L} \frac{dQ}{dt} + \frac{1}{LC} Q = 0 , \quad (4.43)$$

which is the equation for a damped harmonic oscillator, with  $\omega_0 = (LC)^{-1/2}$  and  $\beta = R/2L$ .

The boundary conditions at  $t = 0$  are  $Q(0) = CV$  and  $\dot{Q}(0) = 0$ . Under these conditions, the full solution at all times is

$$Q(t) = CV e^{-\beta t} \left( \cos \nu t + \frac{\beta}{\nu} \sin \nu t \right) \quad (4.44)$$

$$I(t) = -CV \frac{\omega_0^2}{\nu} e^{-\beta t} \sin \nu t . \quad (4.45)$$

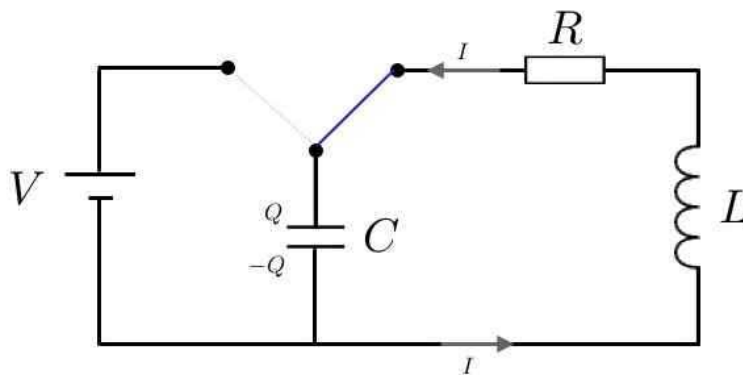

Figure 4.3: An  $R$ - $L$ - $C$  circuit which behaves as a damped harmonic oscillator.



### 4.2.3 Examples

#### Third order linear ODE with forcing

The problem is to solve the equation

$$\mathcal{L}_t x \equiv \ddot{x} + (a + b + c)\dot{x} + (ab + ac + bc)x = f_0 \cos(\Omega t) . \quad (4.46)$$

The key to solving this is to note that the differential operator  $\mathcal{L}_t$  factorizes:

$$\begin{aligned} \mathcal{L}_t &= \frac{d^3}{dt^3} + (a + b + c) \frac{d^2}{dt^2} + (ab + ac + bc) \frac{d}{dt} + abc \\ &= \left( \frac{d}{dt} + a \right) \left( \frac{d}{dt} + b \right) \left( \frac{d}{dt} + c \right) , \end{aligned} \quad (4.47)$$

which says that the third order differential operator appearing in the ODE is in fact a product of first order differential operators. Since

$$\frac{dx}{dt} + \alpha x = 0 \quad \implies \quad x(t) = A e^{-\alpha t} , \quad (4.48)$$

we see that the homogeneous solution takes the form

$$x_h(t) = A e^{-at} + B e^{-bt} + C e^{-ct} , \quad (4.49)$$

where  $A$ ,  $B$ , and  $C$  are constants.

To find the inhomogeneous solution, we solve  $L_t x = f_0 e^{-i\Omega t}$  and take the real part. Writing  $x(t) = x_0 e^{-i\Omega t}$ , we have

$$\mathcal{L}_t x_0 e^{-i\Omega t} = (a - i\Omega)(b - i\Omega)(c - i\Omega)x_0 e^{-i\Omega t} \quad (4.50)$$

and thus

$$x_0 = \frac{f_0 e^{-i\Omega t}}{(a - i\Omega)(b - i\Omega)(c - i\Omega)} \equiv A(\Omega) e^{i\delta} f_0 e^{-i\Omega t} ,$$

where

$$A(\Omega) = \left[ (a^2 + \Omega^2)(b^2 + \Omega^2)(c^2 + \Omega^2) \right]^{-1/2} \quad (4.51)$$

$$\delta(\Omega) = \tan^{-1} \left( \frac{\Omega}{a} \right) + \tan^{-1} \left( \frac{\Omega}{b} \right) + \tan^{-1} \left( \frac{\Omega}{c} \right) . \quad (4.52)$$

Thus, the most general solution to  $L_t x(t) = f_0 \cos(\Omega t)$  is

$$x(t) = A(\Omega) f_0 \cos(\Omega t - \delta(\Omega)) + A e^{-at} + B e^{-bt} + C e^{-ct} . \quad (4.53)$$

Note that the phase shift increases monotonically from  $\delta(0) = 0$  to  $\delta(\infty) = \frac{3}{2}\pi$ .

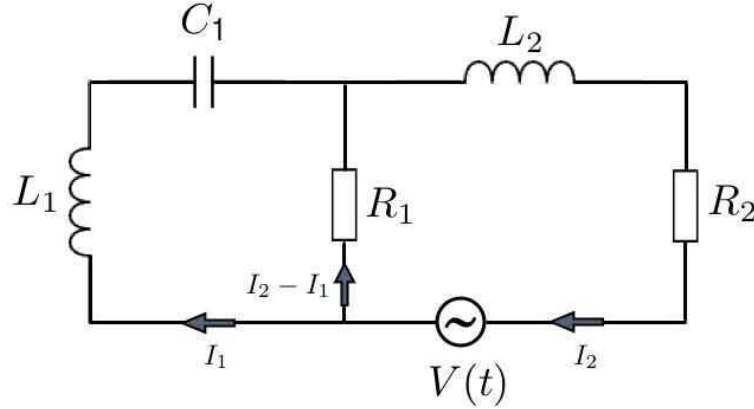

Figure 4.4: A driven  $L$ - $C$ - $R$  circuit, with  $V(t) = V_0 \cos(\omega t)$ .

### Mechanical analog of RLC circuit

Consider the electrical circuit in fig. 4.4. Our task is to construct its mechanical analog. To do so, we invoke Kirchoff's laws around the left and right loops:

$$L_1 \dot{I}_1 + \frac{Q_1}{C_1} + R_1 (I_1 - I_2) = 0 \quad (4.54)$$

$$L_2 \dot{I}_2 + R_2 I_2 + R_1 (I_2 - I_1) = V(t) . \quad (4.55)$$

Let  $Q_1(t)$  be the charge on the left plate of capacitor  $C_1$ , and define

$$Q_2(t) = \int_0^t dt' I_2(t') . \quad (4.56)$$

Then Kirchoff's laws may be written

$$\ddot{Q}_1 + \frac{R_1}{L_1} (\dot{Q}_1 - \dot{Q}_2) + \frac{1}{L_1 C_1} Q_1 = 0 \quad (4.57)$$

$$\ddot{Q}_2 + \frac{R_2}{L_2} \dot{Q}_2 + \frac{R_1}{L_2} (\dot{Q}_2 - \dot{Q}_1) = \frac{V(t)}{L_2} . \quad (4.58)$$

Now consider the mechanical system in Fig. 4.5. The blocks have masses  $M_1$  and  $M_2$ . The friction coefficient between blocks 1 and 2 is  $b_1$ , and the friction coefficient between block 2 and the floor is  $b_2$ . Here we assume a velocity-dependent frictional force  $F_f = -b\dot{x}$ , rather than the more conventional constant  $F_f = -\mu W$ , where  $W$  is the weight of an object. Velocity-dependent friction is applicable when the relative velocity of an object and a surface is sufficiently large. There is a spring of spring constant  $k_1$  which connects block 1 to the wall. Finally, block 2 is driven by a periodic acceleration  $f_0 \cos(\omega t)$ . We now identify

$$X_1 \leftrightarrow Q_1 \quad , \quad X_2 \leftrightarrow Q_2 \quad , \quad b_1 \leftrightarrow \frac{R_1}{L_1} \quad , \quad b_2 \leftrightarrow \frac{R_2}{L_2} \quad , \quad k_1 \leftrightarrow \frac{1}{L_1 C_1} \quad , \quad (4.59)$$

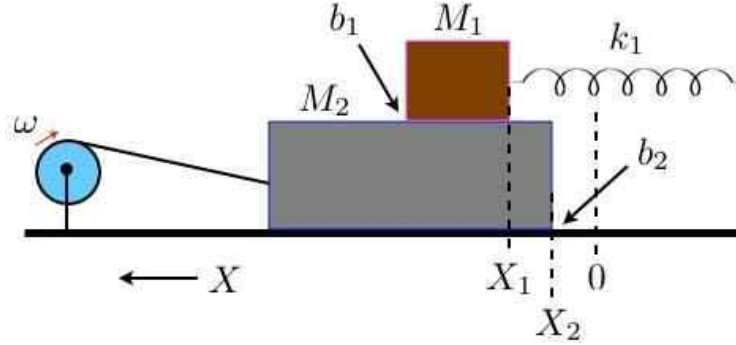

Figure 4.5: The equivalent mechanical circuit for fig. 4.4.

as well as  $f(t) \leftrightarrow V(t)/L_2$ .

The solution again proceeds by Fourier transform. We write

$$V(t) = \int_{-\infty}^{\infty} \frac{d\omega}{2\pi} \hat{V}(\omega) e^{-i\omega t} \quad (4.60)$$

and

$$\begin{Bmatrix} Q_1(t) \\ \hat{I}_2(t) \end{Bmatrix} = \int_{-\infty}^{\infty} \frac{d\omega}{2\pi} \begin{Bmatrix} \hat{Q}_1(\omega) \\ \hat{I}_2(\omega) \end{Bmatrix} e^{-i\omega t} \quad (4.61)$$

The frequency space version of Kirchoff's laws for this problem is

$$\overbrace{\begin{pmatrix} -\omega^2 - i\omega R_1/L_1 + 1/L_1 C_1 & R_1/L_1 \\ i\omega R_1/L_2 & -i\omega + (R_1 + R_2)/L_2 \end{pmatrix}}^{\hat{G}(\omega)} \begin{pmatrix} \hat{Q}_1(\omega) \\ \hat{I}_2(\omega) \end{pmatrix} = \begin{pmatrix} 0 \\ \hat{V}(\omega)/L_2 \end{pmatrix} \quad (4.62)$$

The homogeneous equation has eigenfrequencies given by the solution to  $\det \hat{G}(\omega) = 0$ , which is a cubic equation. Correspondingly, there are three initial conditions to account for:  $Q_1(0)$ ,  $I_1(0)$ , and  $I_2(0)$ . As in the case of the single damped harmonic oscillator, these transients are damped, and for large times may be ignored. The solution then is

$$\begin{pmatrix} \hat{Q}_1(\omega) \\ \hat{I}_2(\omega) \end{pmatrix} = \begin{pmatrix} -\omega^2 - i\omega R_1/L_1 + 1/L_1 C_1 & R_1/L_1 \\ i\omega R_1/L_2 & -i\omega + (R_1 + R_2)/L_2 \end{pmatrix}^{-1} \begin{pmatrix} 0 \\ \hat{V}(\omega)/L_2 \end{pmatrix}. \quad (4.63)$$

To obtain the time-dependent  $Q_1(t)$  and  $I_2(t)$ , we must compute the Fourier transform back to the time domain.

### 4.3 General solution by Green's function method

For a general forcing function  $f(t)$ , we solve by Fourier transform. Recall that a function  $F(t)$  in the time domain has a Fourier transform  $\hat{F}(\omega)$  in the frequency domain. The relation between the two is:

$$F(t) = \int_{-\infty}^{\infty} \frac{d\omega}{2\pi} e^{-i\omega t} \hat{F}(\omega) \iff \hat{F}(\omega) = \int_{-\infty}^{\infty} dt e^{+i\omega t} F(t). \quad (4.64)$$

We can convert the differential equation 4.2 to an algebraic equation in the frequency domain,  $\hat{x}(\omega) = \hat{G}(\omega) \hat{f}(\omega)$ , where

$$\hat{G}(\omega) = \frac{1}{\omega_0^2 - 2i\beta\omega - \omega^2} \quad (4.65)$$

is the *Green's function* in the frequency domain. The general solution is written

$$x(t) = \int_{-\infty}^{\infty} \frac{d\omega}{2\pi} e^{-i\omega t} \hat{G}(\omega) \hat{f}(\omega) + x_h(t), \quad (4.66)$$

where  $x_h(t) = \sum_i C_i e^{-i\omega_i t}$  is a solution to the homogeneous equation. We may also write the above integral over the time domain:

$$x(t) = \int_{-\infty}^{\infty} dt' G(t-t') f(t') + x_h(t) \quad (4.67)$$

$$\begin{aligned} G(s) &= \int_{-\infty}^{\infty} \frac{d\omega}{2\pi} e^{-i\omega s} \hat{G}(\omega) \\ &= \nu^{-1} \exp(-\beta s) \sin(\nu s) \Theta(s) \end{aligned} \quad (4.68)$$

where  $\Theta(s)$  is the *step function*,

$$\Theta(s) = \begin{cases} 1 & \text{if } s \geq 0 \\ 0 & \text{if } s < 0 \end{cases} \quad (4.69)$$

#### Example: force pulse

Consider a pulse force

$$f(t) = f_0 \Theta(t) \Theta(T-t) = \begin{cases} f_0 & \text{if } 0 \leq t \leq T \\ 0 & \text{otherwise.} \end{cases} \quad (4.70)$$

In the underdamped regime, for example, we find the solution

$$x(t) = \frac{f_0}{\omega_0^2} \left\{ 1 - e^{-\beta t} \cos \nu t - \frac{\beta}{\nu} e^{-\beta t} \sin \nu t \right\} \quad (4.71)$$

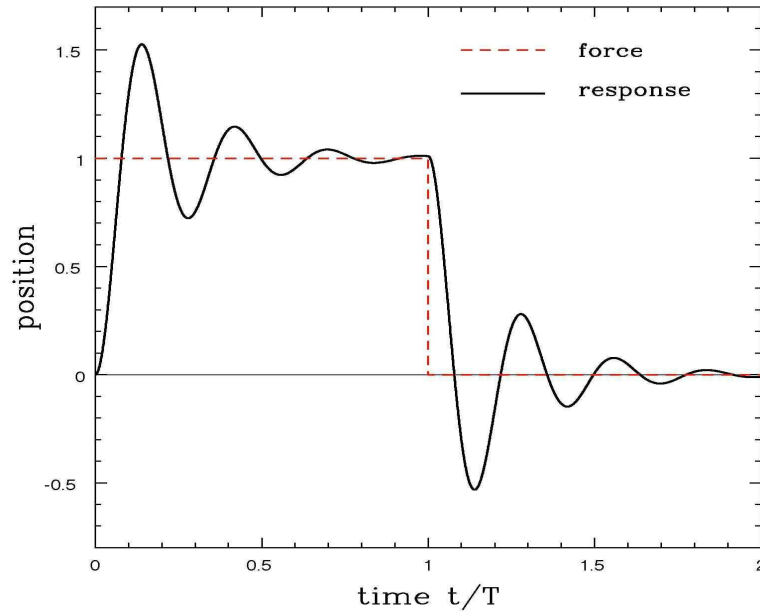

Figure 4.6: Response of an underdamped oscillator to a pulse force.

if  $0 \leq t \leq T$  and

$$x(t) = \frac{f_0}{\omega_0^2} \left\{ \left( e^{-\beta(t-T)} \cos \nu(t-T) - e^{-\beta t} \cos \nu t \right) + \frac{\beta}{\nu} \left( e^{-\beta(t-T)} \sin \nu(t-T) - e^{-\beta t} \sin \nu t \right) \right\} \quad (4.72)$$

if  $t > T$ .

## 4.4 General Linear Autonomous Inhomogeneous ODEs

This method immediately generalizes to the case of general autonomous linear inhomogeneous ODEs of the form

$$\frac{d^n x}{dt^n} + a_{n-1} \frac{d^{n-1} x}{dt^{n-1}} + \dots + a_1 \frac{dx}{dt} + a_0 x = f(t) . \quad (4.73)$$

We can write this as

$$\mathcal{L}_t x(t) = f(t) , \quad (4.74)$$

where  $\mathcal{L}_t$  is the  $n^{\text{th}}$  order differential operator

$$\mathcal{L}_t = \frac{d^n}{dt^n} + a_{n-1} \frac{d^{n-1}}{dt^{n-1}} + \dots + a_1 \frac{d}{dt} + a_0 . \quad (4.75)$$

The general solution to the inhomogeneous equation is given by

$$x(t) = x_h(t) + \int_{-\infty}^{\infty} dt' G(t, t') f(t') , \quad (4.76)$$

where  $G(t, t')$  is the Green's function. Note that  $\mathcal{L}_t x_h(t) = 0$ . Thus, in order for eqns. 4.74 and 4.92 to be true, we must have

$$\mathcal{L}_t x(t) = \overbrace{\mathcal{L}_t x_h(t)}^{\text{this vanishes}} + \int_{-\infty}^{\infty} dt' \mathcal{L}_t G(t, t') f(t') = f(t) , \quad (4.77)$$

which means that

$$\mathcal{L}_t G(t, t') = \delta(t - t') , \quad (4.78)$$

where  $\delta(t - t')$  is the Dirac  $\delta$ -function. Some properties of  $\delta(x)$ :

$$\int_a^b dx f(x) \delta(x - y) = \begin{cases} f(y) & \text{if } a < y < b \\ 0 & \text{if } y < a \text{ or } y > b . \end{cases} \quad (4.79)$$

$$\delta(g(x)) = \sum_{\substack{x_i \text{ with} \\ g(x_i) = 0}} \frac{\delta(x - x_i)}{|g'(x_i)|} , \quad (4.80)$$

valid for any functions  $f(x)$  and  $g(x)$ . The sum in the second equation is over the zeros  $x_i$  of  $g(x)$ .

Incidentally, the Dirac  $\delta$ -function enters into the relation between a function and its Fourier transform, in the following sense. We have

$$f(t) = \int_{-\infty}^{\infty} \frac{d\omega}{2\pi} e^{-i\omega t} \hat{f}(\omega) \quad (4.81)$$

$$\hat{f}(\omega) = \int_{-\infty}^{\infty} dt e^{+i\omega t} f(t) . \quad (4.82)$$

Substituting the second equation into the first, we have

$$\begin{aligned} f(t) &= \int_{-\infty}^{\infty} \frac{d\omega}{2\pi} e^{-i\omega t} \int_{-\infty}^{\infty} dt' e^{i\omega t'} f(t') \\ &= \int_{-\infty}^{\infty} dt' \left\{ \int_{-\infty}^{\infty} \frac{d\omega}{2\pi} e^{i\omega(t'-t)} \right\} f(t') , \end{aligned} \quad (4.83)$$

which is indeed correct because the term in brackets is a representation of  $\delta(t - t')$ :

$$\int_{-\infty}^{\infty} \frac{d\omega}{2\pi} e^{i\omega s} = \delta(s) . \quad (4.84)$$

If the differential equation  $\mathcal{L}_t x(t) = f(t)$  is defined over some finite  $t$  interval with prescribed boundary conditions on  $x(t)$  at the endpoints, then  $G(t, t')$  will depend on  $t$  and  $t'$  separately. For the case we are considering, the interval is the entire real line  $t \in (-\infty, \infty)$ , and  $G(t, t') = G(t - t')$  is a function of the single variable  $t - t'$ .

Note that  $\mathcal{L}_t = \mathcal{L}\left(\frac{d}{dt}\right)$  may be considered a function of the differential operator  $\frac{d}{dt}$ . If we now Fourier transform the equation  $\mathcal{L}_t x(t) = f(t)$ , we obtain

$$\begin{aligned} \int_{-\infty}^{\infty} dt e^{i\omega t} f(t) &= \int_{-\infty}^{\infty} dt e^{i\omega t} \left\{ \frac{d^n}{dt^n} + a_{n-1} \frac{d^{n-1}}{dt^{n-1}} + \dots + a_1 \frac{d}{dt} + a_0 \right\} x(t) \\ &= \int_{-\infty}^{\infty} dt e^{i\omega t} \left\{ (-i\omega)^n + a_{n-1} (-i\omega)^{n-1} + \dots + a_1 (-i\omega) + a_0 \right\} x(t) , \end{aligned} \quad (4.85)$$

where we integrate by parts on  $t$ , assuming the boundary terms at  $t = \pm\infty$  vanish, *i.e.*  $x(\pm\infty) = 0$ , so that, inside the  $t$  integral,

$$e^{i\omega t} \left( \frac{d}{dt} \right)^k x(t) \rightarrow \left[ \left( -\frac{d}{dt} \right)^k e^{i\omega t} \right] x(t) = (-i\omega)^k e^{i\omega t} x(t) . \quad (4.86)$$

Thus, if we define

$$\hat{\mathcal{L}}(\omega) = \sum_{k=0}^n a_k (-i\omega)^k , \quad (4.87)$$

then we have

$$\hat{\mathcal{L}}(\omega) \hat{x}(\omega) = \hat{f}(\omega) , \quad (4.88)$$

where  $a_n \equiv 1$ . According to the Fundamental Theorem of Algebra, the  $n^{\text{th}}$  degree polynomial  $\hat{\mathcal{L}}(\omega)$  may be uniquely factored over the complex  $\omega$  plane into a product over  $n$  roots:

$$\hat{\mathcal{L}}(\omega) = (-i)^n (\omega - \omega_1)(\omega - \omega_2) \cdots (\omega - \omega_n) . \quad (4.89)$$

If the  $\{a_k\}$  are all real, then  $[\hat{\mathcal{L}}(\omega)]^* = \hat{\mathcal{L}}(-\omega^*)$ , hence if  $\Omega$  is a root then so is  $-\Omega^*$ . Thus, the roots appear in pairs which are symmetric about the imaginary axis. *I.e.* if  $\Omega = a + ib$  is a root, then so is  $-\Omega^* = -a + ib$ .

The general solution to the homogeneous equation is

$$x_h(t) = \sum_{i=1}^n A_i e^{-i\omega_i t} , \quad (4.90)$$

which involves  $n$  arbitrary complex constants  $A_i$ . The susceptibility, or Green's function in Fourier space,  $\hat{G}(\omega)$  is then

$$\hat{G}(\omega) = \frac{1}{\hat{\mathcal{L}}(\omega)} = \frac{i^n}{(\omega - \omega_1)(\omega - \omega_2) \cdots (\omega - \omega_n)}, \quad (4.91)$$

and the general solution to the inhomogeneous equation is again given by

$$x(t) = x_h(t) + \int_{-\infty}^{\infty} dt' G(t-t') f(t'), \quad (4.92)$$

where  $x_h(t)$  is the solution to the homogeneous equation, *i.e.* with zero forcing, and where

$$\begin{aligned} G(s) &= \int_{-\infty}^{\infty} \frac{d\omega}{2\pi} e^{-i\omega s} \hat{G}(\omega) \\ &= i^n \int_{-\infty}^{\infty} \frac{d\omega}{2\pi} \frac{e^{-i\omega s}}{(\omega - \omega_1)(\omega - \omega_2) \cdots (\omega - \omega_n)} \\ &= \sum_{j=1}^n \frac{e^{-i\omega_j s}}{i \mathcal{L}'(\omega_j)} \Theta(s), \end{aligned} \quad (4.93)$$

where we assume that  $\text{Im } \omega_j < 0$  for all  $j$ . The integral above was done using Cauchy's theorem and the calculus of residues – a beautiful result from the theory of complex functions.

As an example, consider the familiar case

$$\begin{aligned} \hat{\mathcal{L}}(\omega) &= \omega_0^2 - 2i\beta\omega - \omega^2 \\ &= -(\omega - \omega_+) (\omega - \omega_-), \end{aligned} \quad (4.94)$$

with  $\omega_{\pm} = -i\beta \pm \nu$ , and  $\nu = (\omega_0^2 - \beta^2)^{1/2}$ . This yields

$$\mathcal{L}'(\omega_{\pm}) = \mp(\omega_+ - \omega_-) = \mp 2\nu. \quad (4.95)$$

Then according to equation 4.93,

$$\begin{aligned} G(s) &= \left\{ \frac{e^{-i\omega_+ s}}{i \mathcal{L}'(\omega_+)} + \frac{e^{-i\omega_- s}}{i \mathcal{L}'(\omega_-)} \right\} \Theta(s) \\ &= \left\{ \frac{e^{-\beta s} e^{-i\nu s}}{-2i\nu} + \frac{e^{-\beta s} e^{i\nu s}}{2i\nu} \right\} \Theta(s) \\ &= \nu^{-1} e^{-\beta s} \sin(\nu s) \Theta(s), \end{aligned} \quad (4.96)$$

exactly as before.



## 4.5 Kramers-Krönig Relations (advanced material)

Suppose  $\hat{\chi}(\omega) \equiv \hat{G}(\omega)$  is analytic in the UHP<sup>1</sup>. Then for all  $\nu$ , we must have

$$\int_{-\infty}^{\infty} \frac{d\nu}{2\pi} \frac{\hat{\chi}(\nu)}{\nu - \omega + i\epsilon} = 0, \quad (4.97)$$

where  $\epsilon$  is a positive infinitesimal. The reason is simple: just close the contour in the UHP, assuming  $\hat{\chi}(\omega)$  vanishes sufficiently rapidly that Jordan's lemma can be applied. Clearly this is an extremely weak restriction on  $\hat{\chi}(\omega)$ , given the fact that the denominator already causes the integrand to vanish as  $|\omega|^{-1}$ .

Let us examine the function

$$\frac{1}{\nu - \omega + i\epsilon} = \frac{\nu - \omega}{(\nu - \omega)^2 + \epsilon^2} - \frac{i\epsilon}{(\nu - \omega)^2 + \epsilon^2}. \quad (4.98)$$

which we have separated into real and imaginary parts. Under an integral sign, the first term, in the limit  $\epsilon \rightarrow 0$ , is equivalent to taking a *principal part* of the integral. That is, for any function  $F(\nu)$  which is regular at  $\nu = \omega$ ,

$$\lim_{\epsilon \rightarrow 0} \int_{-\infty}^{\infty} \frac{d\nu}{2\pi} \frac{\nu - \omega}{(\nu - \omega)^2 + \epsilon^2} F(\nu) \equiv \mathcal{P} \int_{-\infty}^{\infty} \frac{d\nu}{2\pi} \frac{F(\nu)}{\nu - \omega}. \quad (4.99)$$

The principal part symbol  $\mathcal{P}$  means that the singularity at  $\nu = \omega$  is elided, either by smoothing out the function  $1/(\nu - \epsilon)$  as above, or by simply cutting out a region of integration of width  $\epsilon$  on either side of  $\nu = \omega$ .

The imaginary part is more interesting. Let us write

$$h(u) \equiv \frac{\epsilon}{u^2 + \epsilon^2}. \quad (4.100)$$

For  $|u| \gg \epsilon$ ,  $h(u) \simeq \epsilon/u^2$ , which vanishes as  $\epsilon \rightarrow 0$ . For  $u = 0$ ,  $h(0) = 1/\epsilon$  which diverges as  $\epsilon \rightarrow 0$ . Thus,  $h(u)$  has a huge peak at  $u = 0$  and rapidly decays to 0 as one moves off the peak in either direction a distance greater than  $\epsilon$ . Finally, note that

$$\int_{-\infty}^{\infty} du h(u) = \pi, \quad (4.101)$$

a result which itself is easy to show using contour integration. Putting it all together, this tells us that

$$\lim_{\epsilon \rightarrow 0} \frac{\epsilon}{u^2 + \epsilon^2} = \pi \delta(u). \quad (4.102)$$

Thus, for positive infinitesimal  $\epsilon$ ,

$$\frac{1}{u \pm i\epsilon} = \mathcal{P} \frac{1}{u} \mp i\pi \delta(u), \quad (4.103)$$

---

<sup>1</sup>In this section, we use the notation  $\hat{\chi}(\omega)$  for the susceptibility, rather than  $\hat{G}(\omega)$

a most useful result.

We now return to our initial result 4.97, and we separate  $\hat{\chi}(\omega)$  into real and imaginary parts:

$$\hat{\chi}(\omega) = \hat{\chi}'(\omega) + i\hat{\chi}''(\omega) . \quad (4.104)$$

(In this equation, the primes do not indicate differentiation with respect to argument.) We therefore have, for every real value of  $\omega$ ,

$$0 = \int_{-\infty}^{\infty} \frac{d\nu}{2\pi} [\chi'(\nu) + i\chi''(\nu)] \left[ \mathcal{P} \frac{1}{\nu - \omega} - i\pi\delta(\nu - \omega) \right] . \quad (4.105)$$

Taking the real and imaginary parts of this equation, we derive the *Kramers-Krönig relations*:

$$\chi'(\omega) = +\mathcal{P} \int_{-\infty}^{\infty} \frac{d\nu}{\pi} \frac{\hat{\chi}''(\nu)}{\nu - \omega} \quad (4.106)$$

$$\chi''(\omega) = -\mathcal{P} \int_{-\infty}^{\infty} \frac{d\nu}{\pi} \frac{\hat{\chi}'(\nu)}{\nu - \omega} . \quad (4.107)$$